



OASIS L241

241kWh Battery Cabinet

User Manual

Preface

Thank you sincerely for purchasing and exploring products developed and manufactured by Shenzhen Sunwoda Energy Technology Co., Ltd. (hereinafter referred to as "Sunwoda"). We genuinely hope that our products and this manual will meet your needs. Your valuable feedback is warmly welcomed, and we will continuously improve and enhance our offerings.

The copyright of this user manual is owned by Sunwoda. All rights not expressly granted herein are reserved. The content is subject to change based on the latest physical product, and revisions may be made without prior notice.

Due to product version upgrades or other reasons, this document may be updated periodically. Unless otherwise agreed, this document serves solely as a product guide. All statements, information, and recommendations provided herein do not constitute any express or implied warranties.

This document and all information contained within are the exclusive property of Sunwoda. No party shall be granted any license to patents, copyrights, trademarks, or other intellectual property rights of the other party through implication, estoppel, or otherwise, based on this document.

For updates or additional information, please contact Sunwoda.

Content

Preface	1
Content	2
I. About This Manual	4
1.1 Attention	4
1.2 Applicable Model	4
1.3 Target Group	5
II. Safety Statement	6
2.1 General Requirement	6
2.2 Installer	6
2.3 Installation Environment	7
2.4 Electrical Connection	7
2.5 Mechanical Installation	8
2.6 Description of the Marking	9
2.7 General Statement	10
III. Product Introduction	13
3.1 System Introduction	13
3.2 Technical Parameter	13
3.3 Single Line Diagram	14
3.4 Machine Structure	15
IV. Transportation, Storage and Unpacking Inspection	18
4.1 Transportation Requirement	18
4.2 Storage Requirement	19
4.3 Unpacking and Delivery Inspection	20
4.3.1 Unpacking	20
4.3.2 Delivery Inspection	21
V. Installation and Wiring	23
5.1 Installation Requirement	23
5.1.1 Installation Environment Requirement	23
5.1.2 Installation Carrier Requirement	25
5.1.3 Installation Angle Requirement	25
5.1.4 Installation Space Requirement	25
5.1.5 Installation Tool Requirement	27
5.2 Mechanical Installation	28
5.2.1 Build the Foundation	28
5.2.2 Foundation Construction Method	29
5.2.3 Handling Equipment	31
5.2.4 Fixed Equipment	35
5.3 Electrical Wiring	37
5.3.1 Wiring Precautions	37
5.3.2 Wire Harness Specification	37

5.3.3 Ground Line Connection	38
5.3.4 Power Line Connection	39
5.3.5 Communication Line Connection	41
5.4 Installation Inspection	44
5.4.1 Electrical Inspection	44
5.4.2 Structural Inspection	44
VI. Equipment Operation	45
6.1 Indicator Light Introduction	45
6.1.1 Cabinet Indicator Light	45
6.2 Operation Guidance	45
6.2.1 Pre-operation Inspection	45
6.2.2 Power-up Procedure	46
6.2.3 Turn off the Power	49
6.2.4 Emergency Shutdown	49
VII. Maintenance Guidance	50
7.1 Maintenance Precautions	50
7.2 Maintenance Content	50
VIII. Fault Handling	52

I. About This Manual

1.1 Attention

This product is a specialized power distribution equipment. To ensure correctness and safety of installation, use and other operations, be sure to read this manual thoroughly before starting operations. The installer should be professionally trained with a background in electrical technology and be familiar with local grid codes and related requirements. We will not be held liable for any form of damage or injury resulting from failure to follow the operating instructions highlighted in this manual.







This manual is centered around the OASIS L241 series and details its product features, installation specifications, usage practices, troubleshooting, and routine maintenance. Due to product iteration, the contents of the manual will be constantly updated, the specific product details also please refer to the actual product purchased.

Finally, we hope that this product can fully meet your needs, and we also look forward to your valuable comments on this product. If you have any requests, please feel free to feedback us.

1.2 Applicable Model

This manual applies to the following product models:

OASIS L241 : Oasis-L241

SUNWODA ENERGY 深圳市欣旺达能源科技有限公司 Sunwoda Energy Technology Co., Ltd.	
Product Name	Rechargeable Lithium Iron Phosphate Battery System
Battery Type	LiFePO ₄
Rated Capacity	314Ah
Model No. /Nominal Voltage/Rated Energy	
<input type="checkbox"/> Oasis-L48	153.6Vdc/48kWh IFpP72/175/208[48S]M/-30+50/90
<input type="checkbox"/> Oasis-L96	307.2Vdc/96kWh IFpP72/175/208[(48S)2S]M/-30+50/90
<input type="checkbox"/> Oasis-L144	460.8Vdc/144kWh IFpP72/175/208[(48S)3S]M/-30+50/90
<input type="checkbox"/> Oasis-L192	614.4Vdc/192kWh IFpP72/175/208[(48S)4S]M/-30+50/90
<input type="checkbox"/> Oasis-L241	768.0Vdc/241kWh IFpP72/175/208[(48S)5S]M/-30+50/90
<input type="checkbox"/> Oasis-L289	921.6Vdc/289kWh IFpP72/175/208[(48S)6S]M/-30+50/90
<input type="checkbox"/> Oasis-L337	1075.2Vdc/337kWh IFpP72/175/208[(48S)7S]M/-30+50/90
<input type="checkbox"/> Oasis-L385	1228.8Vdc/385kWh IFpP72/175/208[(48S)8S]M/-30+50/90
Short Circuit Current/Time	8000A/4ms
Ambient Temperature	-30°C~55°C
Relative Humidity	5% RH~95% RH
IP Grade	IP55
Protective Class	I
   SN:    	

Note: The above nameplate is for reference only. Actual specifications are subject to the physical product.

1.3 Target Group

This product should only be operated by a professional who has the following basic competencies:

- (1) Professional training on how to deal with the hazards and risks arising during the installation and use of electrical equipment.
- (2) Understand the installation and commissioning of conventional electrical equipment and related devices, and understand the specification requirements of local regulations and standards.
- (3) Possess professional electrical certifications.

II. Safety Statement

2.1 General Requirement

- (1) Before installing the equipment, disconnect the loads and grid circuits and turn the equipment off. Avoid major injuries to personnel or major damage to equipment.
- (2) Static electricity may cause irreversible damage to the internal components of the equipment. When using the product, be sure to comply with the electrostatic protection specifications.
- (3) This product cannot be used to connect life support equipment and medical equipment directly. To ensure your safety and compliance, please consult the supplier in advance of purchase.
- (4) Before the product is turned on, please check the equipment and do not leave installation tools or other unnecessary items inside the cabinet to avoid damage to the equipment after powering on.
- (5) Maintenance equipment, be sure to ensure that the equipment has been safely disconnected from the power supply, and wait for the machine to all the electrically charged devices discharged (more than 10min), so as not to cause significant damage.

2.2 Installer

- (1) All operations of the equipment must be carried out by professional, qualified technicians who have undergone special training and have professional electrical certificates, and the technicians should be familiar with the relevant standards and safety codes of the project location.
- (2) The operator should read this document before installation and understand the structure, working principle and precautions of the product in detail before starting operation.
- (3) In order to ensure personal safety, please wear personal protective equipment and prepare the insulating tools that need to be used before starting to operate the equipment. Personal protective equipment includes safety clothing, safety helmet, safety shoes, insulated gloves, goggles, etc., and insulated tools can be prepared with an insulating layer including the handle of the tool.
- (4) To ensure equipment safety, it is necessary to wear an anti-static wristband, gloves, and clothing when operating electronic devices.

2.3 Installation Environment

- (1) In order to avoid the disturbance of the noise of the equipment operation, it is necessary to install the equipment in an area far away from the residents' life, not less than 50m.
- (2) In order to ensure heat dissipation, the equipment should be in a well-ventilated space (not less than 50m³), to avoid the surrounding airflow.
- (3) In order to facilitate maintenance, the equipment should leave enough space around, see chapter 5.1 for details.
- (4) To ensure normal operation, the ambient temperature of the equipment should be between -30°C~55°C.
- (5) To extend the service life, as far as possible to avoid equipment in the smoke, dust and other particles in the environment (air pollution index < 300), to ensure that the environment around the product is clean and tidy.
- (6) In order to avoid equipment failure, the equipment should be installed in the area away from the liquid (not less than 50m). It is prohibited to install it below the water pipes, air outlets and other locations that are prone to condensation; it is prohibited to install it below the air conditioning outlets, vents, computer room outlet windows and other locations that are prone to water leakage.
- (7) To avoid major damage, do not place flammable or explosive items around the equipment. The equipment should be kept away from any heat and fire sources.
- (8) When the equipment is in operation, do not cover the air vents, heat dissipation system or use other items to cover them.

2.4 Electrical Connection

- (1) The installation of the product should meet the requirements of local power grid regulations and safety codes.
- (2) Product operation involves the risk of high voltage electric shock, only electricians with specialized skills should operate the equipment.

-
- (3) To avoid high voltage breakdown, do not touch the conductors connected to the grid circuit.
 - (4) Wear a static electricity bracelet when operating the electronic components inside the equipment.
 - (5) It is prohibited to damage the grounding conductor and to operate the equipment without the grounding conductor installed.
 - (6) When installing, operating, or maintaining the equipment, it is prohibited to wear watches, bracelets, bangles, rings, necklaces, and other easily conductive objects to avoid electric shock burns.
 - (7) The voltage at the point of contact should be measured before contacting any conductor surface or terminal to ensure that there is no danger of electric shock.
 - (8) Solvents such as water, alcohol or oil are prohibited to clean electrical parts inside and outside the cabinet.
 - (9) In the process of equipment operation, such as the discovery of faults that may lead to personal injury or equipment damage, should immediately terminate the operation, report to the person in charge, and take effective protection measures.
 - (10) Do not power up the equipment before installation is completed or confirmed by a professional.

2.5 Mechanical Installation

- (1) Considering the weight of the equipment, the person who carries out the lifting or forklift loading operation needs to carry out the relevant training and be qualified before taking up the job.
- (2) Work at height shall wear a helmet, safety belt or waist rope, tied to a solid and sturdy structural components, is strictly prohibited to move hanging on the unsound objects or sharp edges of the metal, to prevent the hook slipped off the fall accident.
- (3) The lifting tools must be inspected, the tools need to be prepared and qualified by professional organizations, prohibit the use of scarred, unqualified or beyond the inspection of the validity of the tools to ensure that the tools are solid, and can bear the weight of the equipment.
- (4) Before installing the equipment into the cabinet, first make sure that the other cabinets have been

fixed to avoid the other cabinets from tilting and collapsing due to the unstable center of gravity, resulting in injuries to the installers and the equipment falling and breaking and other problems.

(5) When loading and transporting products, be careful of equipment that may be unstable or very heavy when installed in the product, and lock the front door tightly before starting transportation to avoid being crushed or smashed.

(6) Drilling holes in the equipment is strictly prohibited. Drilling holes will damage the sealing, electromagnetic shielding performance, internal devices and cables of the equipment, and metal shavings from drilling holes into the equipment will lead to a short circuit of the circuit board.



(7) Because the equipment is heavy, it is recommended that the power cables be laid before moving the equipment to its intended location. Because these cables are thick, it will be difficult to perform cable routing operations once the equipment is installed.











(8) When installing the equipment, please make sure that the bottom carrier of the cabinet is strong and reliable and can carry the weight of the cabinet to avoid damage to the equipment.

2.6 Description of the Marking

For personal and equipment safety, follow the safety precautions marked on the equipment when installing, operating, and maintaining the equipment. If the relevant markings become unclear due to long-term use, replace them promptly. The categories of markings and symbols on the product are as follows.

Identifier

Symbol	Description
	Read the user manual before operation or maintenance!
	High voltage hazard! Do not touch!
	Caution! Potential danger!

	Warning: Dangerous arc!
	High temperature! Do not touch!
	Risk of corrosion!
	AC (Sinusoidal waveform)!
	DC power!
	Protective grounding!
	Wear protective gloves!
	No open flames or sparks!
	Do not step on!
	Recyclable!
	The equipment needs to be recycled at the end of its life.
	Danger! Do not touch! Access restricted to authorized personnel only!

2.7 General Statement

Before transporting, storing, installing, operating, using, or maintaining the equipment, please read this manual carefully, follow its instructions strictly, and comply with all safety notices on the equipment and in this manual. In this manual, “equipment” refers to the products, software, components, spare parts, and/or services described here in; “the Company” refers to the manufacturer (producer), seller, and/or service provider of the equipment; and “you” refers to any

person or entity responsible for transporting, storing, installing, operating, using, or maintaining the equipment.

The terms “Danger”, “Warning”, “Caution”, and “Notice” in this manual do not represent all safety requirements, you must also comply with applicable international, national, or regional standards, as well as industry best practices. The Company assumes no responsibility for any consequences resulting from failure to comply with safety requirements or from violations of design, production, or equipment use standards.

The equipment must be used in an environment that meets the design specifications. Failure to do so may result in equipment malfunction, abnormal operation, or component damage, which are not covered under the equipment’s quality warranty. The Company is not liable for any personal injury, property damage, or other losses that may result from improper use.

This equipment is not designed to be used as a life-support system, medical equipment, mobile vehicle, ship, aircraft, emergency rescue, drilling, mining, or any other operation where product failure could result in personal injury, loss of life, or serious property damage, whether as a primary or backup power source. The Company assumes no liability for any consequences arising from such use of this equipment. Furthermore, The Company reserves the right to refuse service to any equipment used for these purposes and shall not be liable for any consequences resulting from providing or refusing service under such circumstances.

All operations, including transportation, storage, installation, operation, use, and maintenance, must comply with applicable laws, regulations, standards, and normative requirements.

Reverse engineering, decompiling, disassembling, modifying, implanting, or creating derivative works from the equipment software is strictly prohibited. You may not study the internal logic, obtain the source code, infringe on intellectual property rights, or disclose any software performance test results in any manner.

The Company shall not be held responsible for any damage or consequences resulting from the following:

- Equipment damage caused by earthquakes, floods, volcanic eruptions, landslides, lightning, fire, war, armed conflicts, typhoons, hurricanes, tornadoes, extreme weather, or other force majeure events.

- Operation outside the conditions specified in this manual.

- Installation or operating environments that do not comply with applicable international, national, or regional standards.

- Installation or operation by unqualified personnel.

- Failure to follow product instructions, operational guidelines, or safety warnings.

- Unauthorized disassembly, modification of the product, or alteration of software code.

- Damage caused during transportation by you or a third party commissioned by you.

- Damage resulting from storage conditions that do not meet the product documentation requirements.

- Use of materials or tools that do not comply with local laws, regulations, or relevant standards.

- Damage caused by negligence, intentional acts, gross misconduct, improper operation, or reasons not attributable to the Company by you or a third party.

III. Product Introduction

3.1 System Introduction

OASIS L241 industrial and commercial series products are high-security, high-reliability, standardized series products developed for industrial and commercial application scenarios. It adopts modular system configuration to flexibly match all kinds of industrial and commercial scenarios, and with a variety of energy storage inverters, it can support on-grid, off-grid, and on-off grid scenarios; and it supports parallel expansion, which is convenient for system expansion, and it can realize the shift of peaks and valleys and the staggered peaks of electricity consumption, and alleviate the pressure on the power grid.

Products include battery box, control box,, battery management system, fire protection system, etc.

3.2 Technical Parameter

Product Series	OASIS L241
Product Model	Oasis-L241
Battery Side Parameter	
Cell Type	LFP
Cell Specification	3.2V 314Ah
PACK Capacity	48.2kWh
Nominal Capacity	241kWh
Nominal Voltage	768V
Voltage Range	648~864V
System Parameter	
Communication Interface	LAN、CAN
Display	Touchscreen, Cloud Platform
Protection Rating	IP55
Cooling Method	Liquid cooling
Installation Type	Outdoor
Corrosion Resistance	C4
Ambient Temperature	-30°C ~ 55°C (>45°C derating)
Humidity	5% ~ 95% (non-condensing)
Noise	<75dB
Altitude	2000m
Size (W×D×H)	1570*1350*2466mm (Including lifting ring)
Weight	2520kg±50kg

3.3 Single Line Diagram

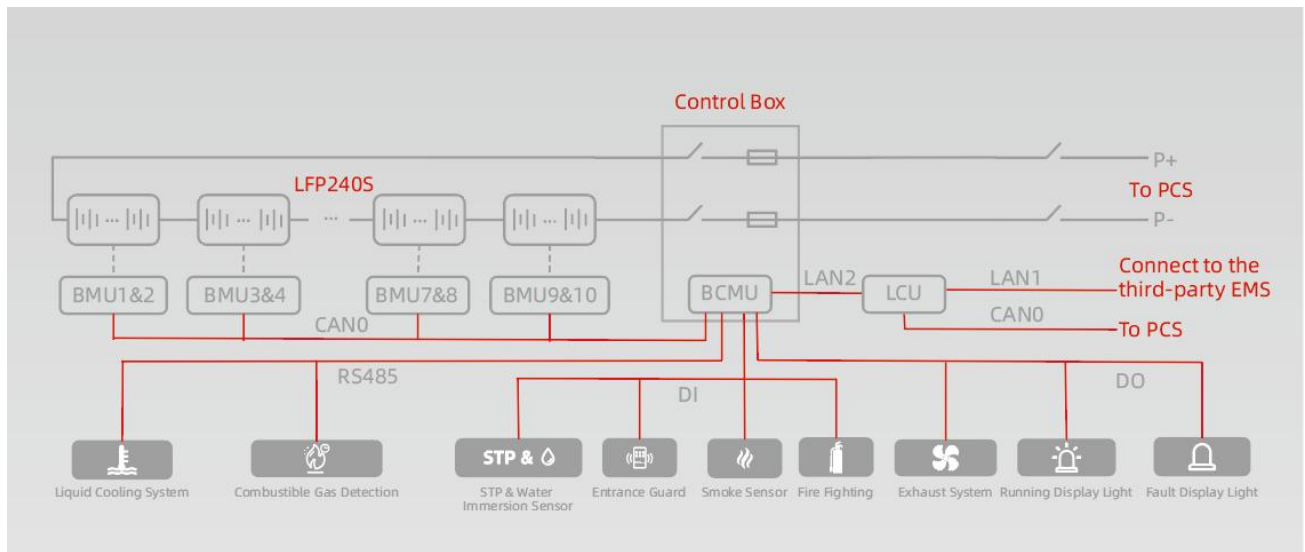

3.4 Machine Structure

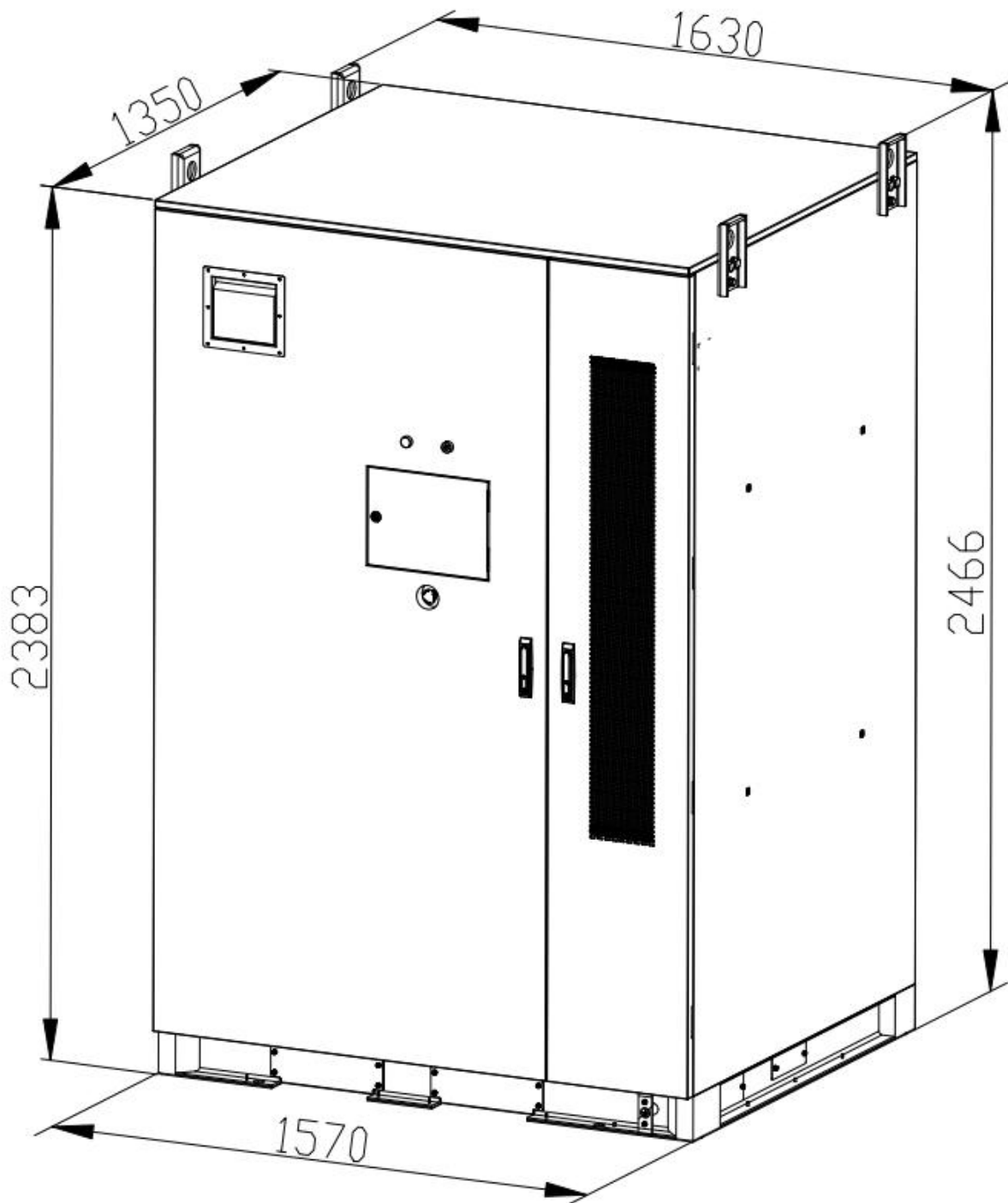

Figure 3.4.1 Schematic of Cabinet Dimension

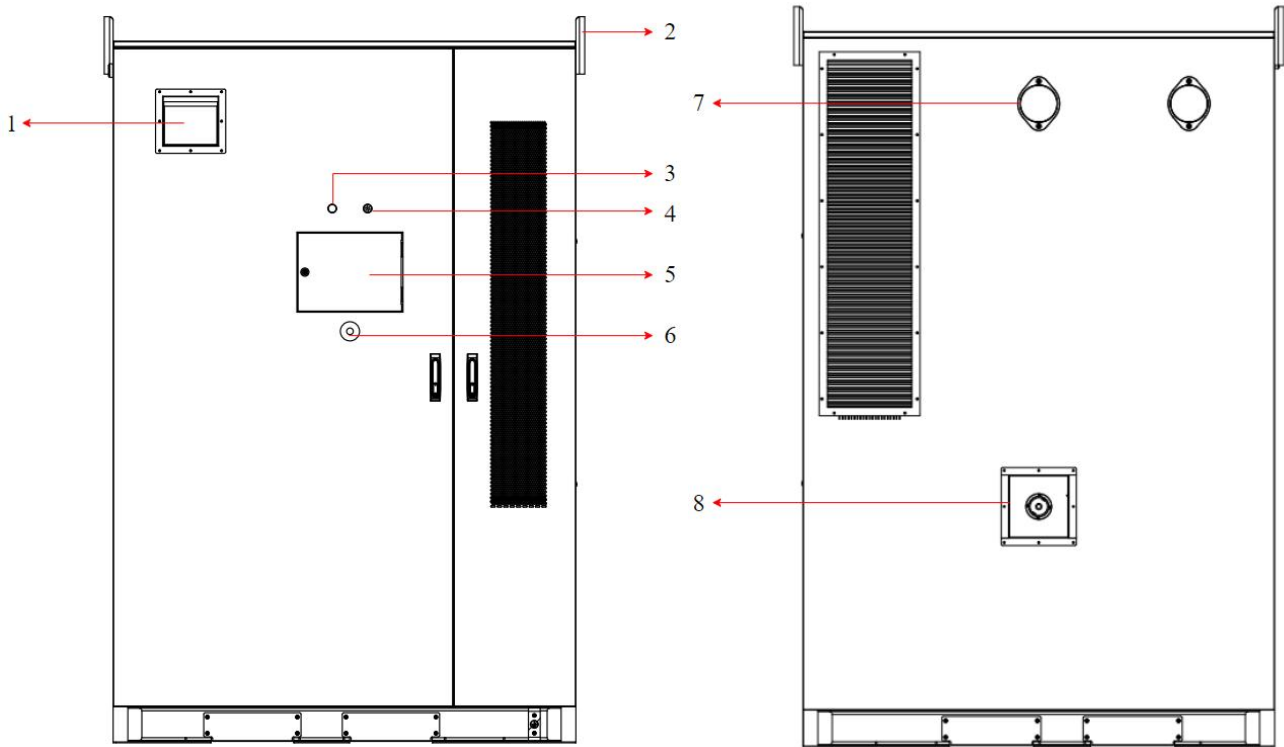

Figure 3.4.2 Main View and Back View

NO.	Name	NO.	Name
1	Combustible Gas Exhaust Fan	5	Touch Screen
2	Lifting Ring	6	Emergency Stop Switch
3	Run Indicator Light	7	Explosion-proof Valve
4	Fault Indicator Light	8	Water Fire Protection Interface

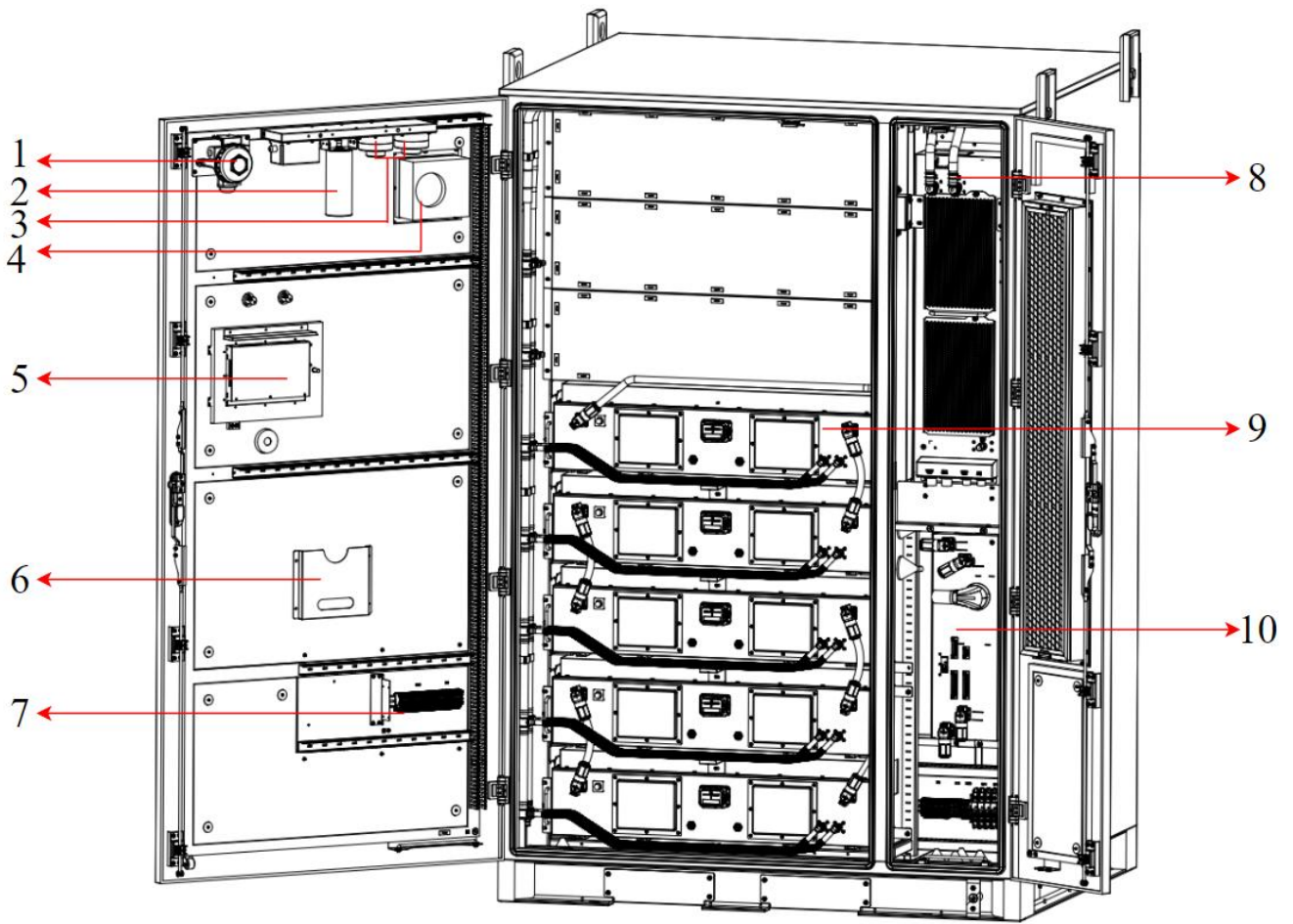

Figure 3.4.3 Internal Layout Diagram

NO.	Name	NO.	Name
1	Combustible Gas Detector	6	File Box
2	Aerosol Fire Suppression	7	Terminal Block
3	Smoke Sensation、 Temperature Sensation	8	Liquid Cooling Unit
4	Combustible Gas Exhaust Fan	9	Battery PACK
5	Touch Screen	10	Control Box

IV. Transportation, Storage and Unpacking Inspection

4.1 Transportation Requirement

Improper transportation may cause injuries or equipment damage, when transporting, please be sure to follow the following transportation requirements:

(1) Please check whether the package is intact before transportation. If you find any signs of damage, do not open the package and contact your supplier.

(2) Only professionally trained and instructed personnel should carry out transportation operations on public roads.

(3) Whenever possible, transport the product in its packaging and follow the safety regulations indicated on the packaging.

(4) Please use appropriate fixing devices, such as ropes, support frames, etc., during transportation to ensure that the equipment will not be shifted due to shaking or vibration during transportation.

(5) Keep the equipment upright during transportation. Do not allow the equipment to be placed horizontally or reverse upside down, so as to avoid the internal modules of the equipment sliding and causing damage to the equipment.

(6) The tilt angle of the equipment when placed upright should be less than 5° .

(7) The equipment should be transported as a complete unit. Any detachment of the system without our permission and consequent damage to the equipment is not covered by the warranty.

(8) Avoid severe vibration, shock or crushing during transportation. Sudden lowering or lifting is also not allowed. Please minimize bumps and tilts during transportation.

(9) Please refer to the front-facing sign on the cabinet for the direction of transportation of the equipment, and avoid inverting, tilting, dropping, mechanical impact, rain, snow and falling into water.

(10) Comply with the international road transportation rules and meet the regulatory requirements of the transportation regulatory authorities of the country of origin, route and destination.

(11) The transportation should choose sea transportation or road with good condition, and do not support railroad and air transportation.

(12) The loading, unloading and handling process during transportation must be carried out by professional personnel.

(13) Please pay attention to the loading and unloading and handling process during transportation, so as to avoid damage to the equipment or personnel.

(14) Be sure to wear appropriate personal protective equipment, such as helmets and non-slip shoes, during loading, unloading and handling during transportation.

(15) During transportation, make sure the foundation is protected from moisture if necessary.

(16) The loading, unloading, and handling process during transportation can be carried out by forklift, crane, or wheelbarrow, etc., and a trial loading and lifting can be carried out to ensure the load-bearing capacity of the loading equipment when forklifting or lifting.

(17) Please arrange auxiliary personnel during the handling process to avoid the situation that the equipment size is too big to block the driver's sight.

(18) Please pay attention to the center of gravity of the equipment and keep the equipment balanced.

4.2 Storage Requirement

If the product is not installed on site immediately after arrival, the product should be stored with the outer packaging and the following matters should be followed:

Warning

(1) Store the battery indoors. No direct sunlight or rain, no extreme cold or heat, dry and well ventilated, away from heat and fire sources.

(2) If the battery is bulging, deformed, broken or leaking, it shall be scrapped without regard to the storage time.

(3) When storing the battery, it should be placed correctly according to the identification of the packing box, and it is strictly prohibited to place it upside down, sideways, or at an angle, and when stacking it, it should conform to the yardage requirements on the outer packaging.

(4) The site must be equipped with fire-fighting facilities that meet the requirements, such as firefighting sand and fire extinguishers.

 **Warning**

(1) Batteries are recommended to be used in a timely manner. For batteries that have been stored for a long period of time, please carry out regular replenishment of electricity, otherwise the batteries may be damaged.

(2) The ambient air must not contain corrosive or flammable gases, the surrounding environment is clean, there is no large amount of infrared and other radiation, no organic solvents or corrosive gases, and there is no metallic conductive dust.

 **Notice**

(1) During storage, it is necessary to keep relevant proof of compliance with product storage requirements, such as temperature and humidity log data, photos of the storage environment and inspection reports.

(2) Store in a clean and dry place and protect from dust and moisture. Prohibit erosion by rain or ground water.

(3) Storage environment requirements:

Recommended storage temperature: 20°C~30°C.

Relative humidity: 5% RH~80% RH.

Dry, ventilated and clean. Avoid contact with corrosive organic solvents, gases and other substances.

Avoid direct sunlight. The distance from the heat source should not be less than two meters.

(4) From the date of shipment from the manufacturer, the battery needs to be maintained at intervals of up to 12 months, and the desiccant inside it should be replaced in a timely manner.

4.3 Unpacking and Delivery Inspection

4.3.1 Unpacking

Once the product has been transported to the vicinity of the installation site, unpack it and check that the delivery items are complete.

Step1. Remove the bolts on the four cabinet feet at the bottom of the packing crate.

Step2. Remove the top and side panels of the crate.



Step3. Remove the external packing materials from the product.

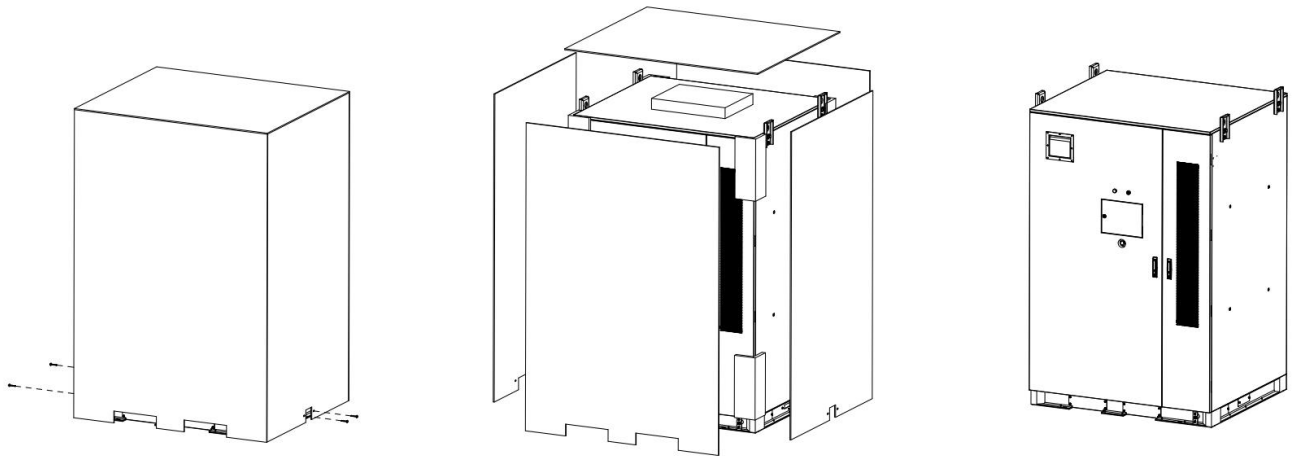







Step4. Open the front door of the product and check whether the delivered items are complete.



4.3.2 Delivery Inspection

Please check against the packing list to see if the items received are complete. The actual pictures of the items are as follows (please refer to the actual shipment):

NO.	Name	Description	Quantity	Reference Picture	Note
1	Certificate of Conformity	/	1		
2	DC Cable	BAT+\BAT-	4		PACK to PACK connection
3	Negative Quick-Connect Plug	ES103-03C70-1SYW-06, black, for 70mm ² cable	1		
		ES103-03C50-1SYW-06, black, for 50mm ² cable	1		
4	Positive Quick-Connect Plug	ES103-03C70-2SYX-06, orange, for 70mm ² cable	1		
		ES103-03C50-2SYX-06, orange, for 50mm ² cable	1		
5	Maintenance Switch Plug	RC-MSD12-TP-A 1500VDC 350A	5		

6	CAN Box	USBCAN- II	1		
7	LCU Door Key	Supporting facilities	1		
8	Cabinet Door Key	Supporting facilities	4		
9	L-wrench	/	2		Cabinet Door Accessories
10	Magnetic Pen	/	1		Combustible Gas Detector Accessories
11	L-wrench	/	1		Combustible Gas Detector Accessories
12	Hex Head Bolt Assembly	M6*20	12		
13	Forklift Hole Cover Plate	Supporting facilities	5		

V. Installation and Wiring

5.1 Installation Requirement

5.1.1 Installation Environment Requirement

- (1) It must not be installed in flammable, explosive, or corrosive environments.
- (2) The installation location should avoid areas where children are active, to prevent accidental contact or injury.
- (3) The installation space must meet the equipment's ventilation, heat dissipation, and operational space requirements.
- (4) The installation height should allow for easy maintenance, ensuring that labels and indicator lights are clearly visible and terminals are easily accessible.
- (5) Suitable for operation at altitudes below 2000 m, with a temperature range of -30°C to 55°C (derating above 45°C).
- (6) The installation foundation must be level, solid, flame-retardant, and capable of supporting the equipment's full-load weight and dynamic stress.
- (7) A maintenance clearance of no less than 0.5 m must be reserved around the energy storage system, and a vertical clearance of no less than 0.5 m above it for ventilation and operation.
- (8) The equipment must be properly grounded, with grounding resistance not exceeding 4Ω, and must comply with local electrical safety regulations.
- (9) Firefighting equipment meeting fire protection requirements (such as aerosol, heptafluoropropane, or ammonium phosphate dry powder extinguishers) must be provided at the installation site and placed in easily accessible locations.
- (10) It is prohibited to install the energy storage system in low-lying areas prone to flooding, water accumulation, or poor drainage. The system should be installed away from liquids and must not be

placed under water pipes, air outlets, or other locations prone to condensation or leakage, to prevent liquid ingress that could cause failure or short circuits.

(11) Site selection and installation must comply with local energy storage standards and fire regulations. The site should have convenient transportation access, with surrounding roads accessible to fire trucks. Locations must avoid, including but not limited to, historical and cultural heritage protection areas, densely populated places, high-rise buildings, underground buildings, and areas with existing underground facilities.

(12) There must be no vegetation or flammable materials within 3 meters of the installation site and the surrounding area.

(13) The distance between the energy storage system and flammable/explosive hazard sources (such as fuel dispensers, oil tanks, gas tanks, hydrogen refueling equipment) must be ≥ 10 meters.

(14) The distance between the energy storage system and key locations such as main entrances/exits of densely populated places (schools, hospitals, hotels, shopping centers, etc.) must be ≥ 3 meters.

(15) The system must not be installed in locations subject to vibration, shock, or frequent movement (e.g., directly next to large stamping equipment or near railway tracks without isolation).

(16) The installation location should avoid enclosed or semi-enclosed spaces where flammable gases may accumulate. If unavoidable, gas detection and linked ventilation systems must be installed.

(17) The system must not be installed in areas with severe salt spray corrosion (such as unprotected coastal exposure) or heavy dust that may lead to conductive dust accumulation, unless additional protective measures are taken.

(18) The equipment must not be placed near heat or fire sources such as open flames, hot air outlets, heaters, or other heat-generating equipment, as overheating may cause damage or fire.

5.1.2 Installation Carrier Requirement

- (1) It is recommended to build a foundation to install the product.
- (2) Do not mount the equipment to flammable materials. The mounting carrier must be fire resistant.
- (3) The mounting carrier must be reliable and sufficient to carry the weight of the equipment.
- (4) There may be slight vibration during the operation of the equipment. Do not install the equipment on a carrier with poor sound insulation, so as to prevent the noise of the equipment operation from affecting the people in the surrounding area.

5.1.3 Installation Angle Requirement

The equipment should be installed horizontally and vertically, not tilted or inverted.

5.1.4 Installation Space Requirement



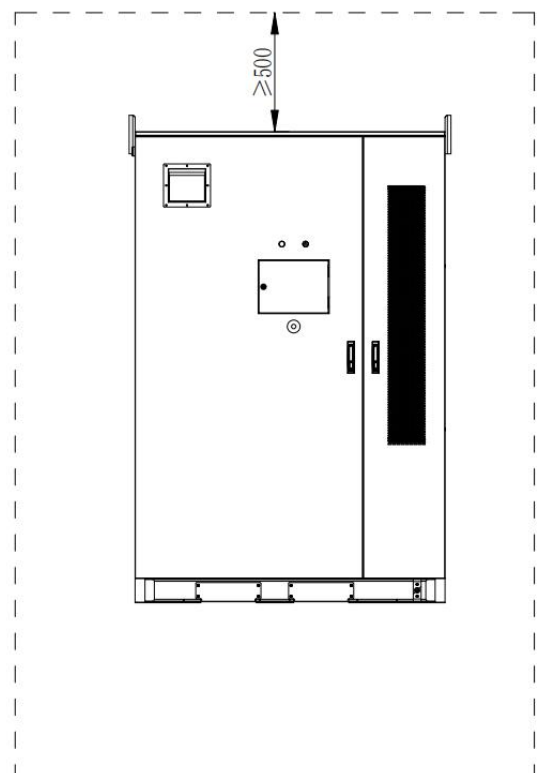
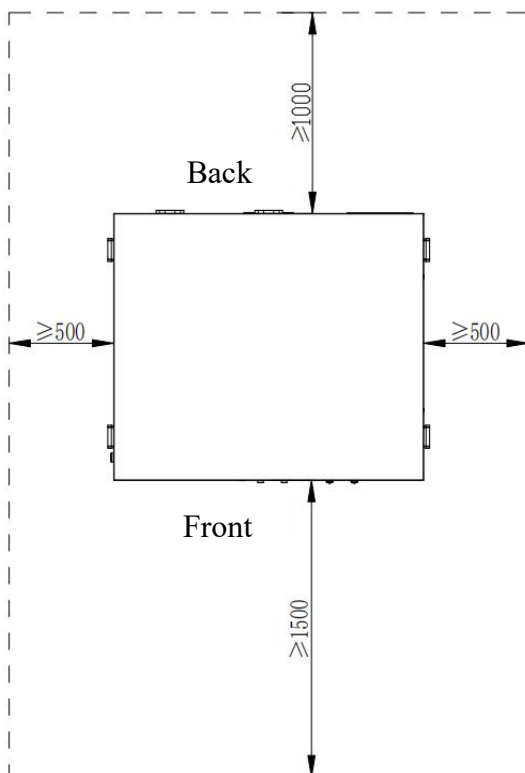

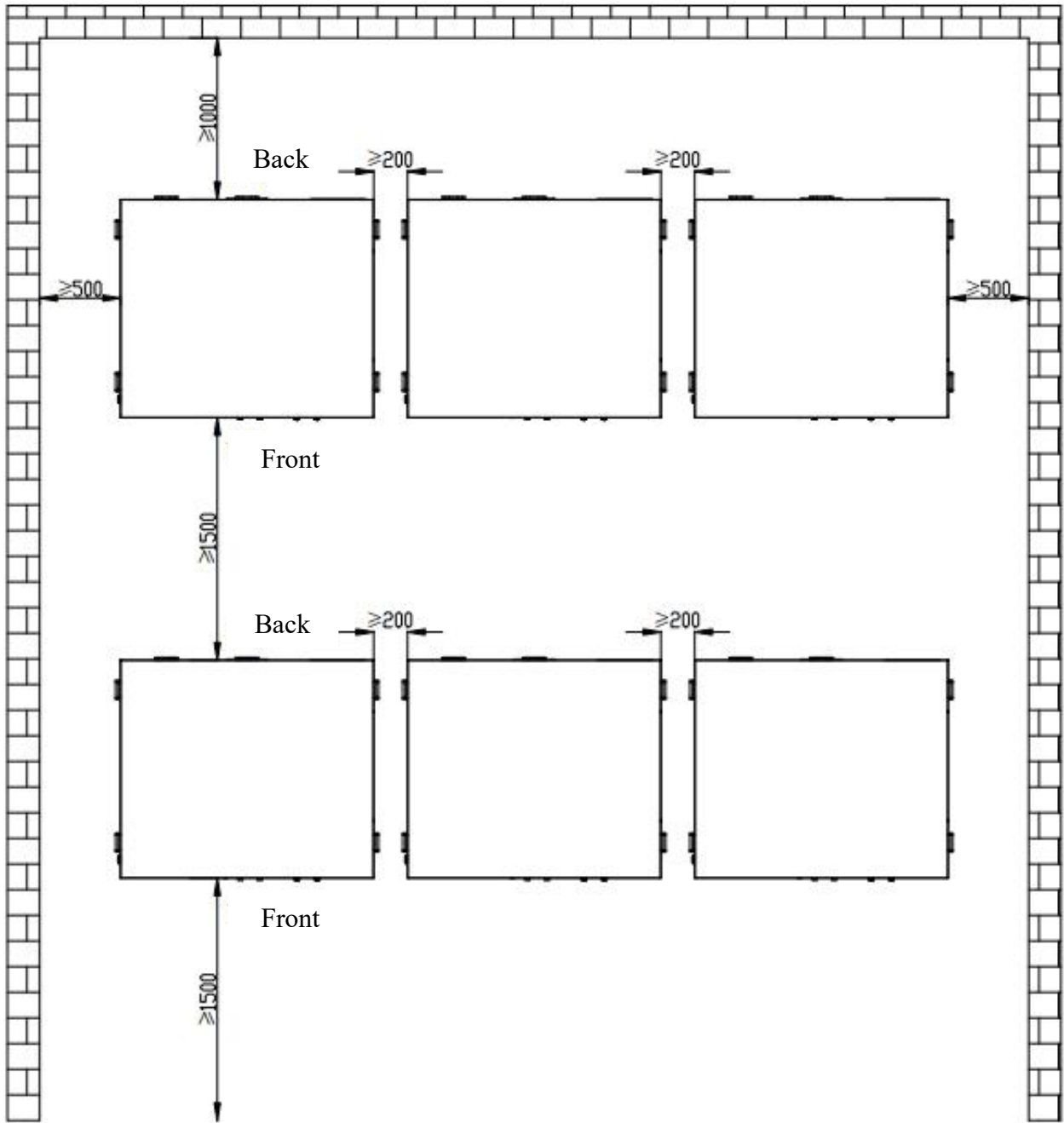
When installing the equipment, please observe the following peripheral space reservation requirements while taking into account the footprint of the equipment:









5.1.5 Installation Tool Requirement

(1) Protective Tool

				
Insulated Gloves	Labor Protection Gloves	Safety Helmets	Insulated Shoes	Reflective Safety Jacket

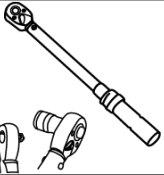
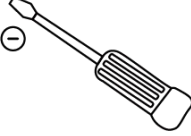
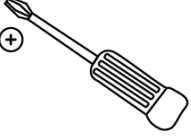
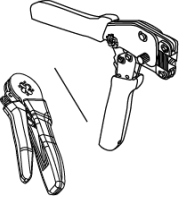
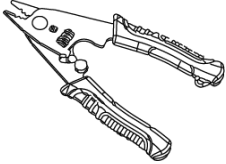
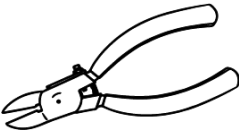
Note: The above is for reference only and is inclusive and not limited to.

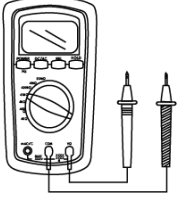
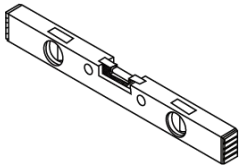
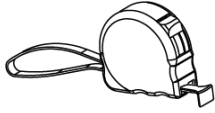
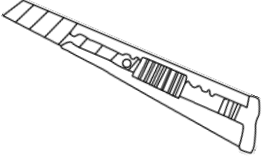
(2) Mounting Tool

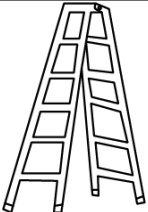
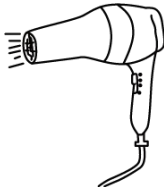
			
Forklift(≥3t)	Insulated Torque Wrench (10~50N•m)	Flathead Screwdriver	Phillips Screwdriver
			
Crimping Pliers (7", hexagonal, 0.25~6mm ²)	Wire Stripper (7")	Wire Cutter (5")	Rubber Hammer (50mm)
			
Multimeter (15B MAX-01, DC1000V)	Level Ruler (500mm)	Steel Tape Measure (5m)	Art Knife
			
Marker Pen	Insulated Ladder (>2m)	Hot Air Dryer (1600W)	

Note: The above is for reference only and is inclusive and not limited to.

5.2 Mechanical Installation

5.2.1 Build the Foundation

(1) Location selection

When choosing the foundation site, please at least follow the following principles:

The climatic environment and geological conditions (such as stress wave emission and groundwater level) of the installation site of the energy storage integrated system should be fully considered.

The surrounding environment is dry, well-ventilated and far away from flammable and explosive areas.

The soil at the installation site needs to have a certain degree of compaction. It is recommended that the relative density of the soil at the installation site be $\geq 98\%$. If the soil is loose, be sure to take measures to ensure the stability of the foundation.

(2) Foundation requirements

An unreasonable foundation construction plan will bring significant difficulties or troubles to the placement, door opening and closing, and later operation of the energy storage integrated system. Therefore, the installation foundation of the energy storage integrated system must be designed and constructed in advance in accordance with certain standards to meet the requirements of mechanical support, cable routing, and later maintenance and repair.

When building the foundation, at least the following requirements should be met:

The bottom of the foundation pit for building the foundation must be filled and compacted.

The foundation should be sufficient to provide effective support for the equipment. The load-bearing capacity of the foundation must not be less than 5 tons.

The foundation should meet the minimum floor area required for the cabinet.

The construction ground should be flat and even without any slope to prevent uneven structural stress or door deformation caused by the tilt of the cabinets.

The construction ground should be designed with a slope or drainage ditches to prevent rainwater accumulation.

The product needs to be installed on a concrete foundation or a structure supported by channel steel with a flame-retardant surface. It is necessary to ensure that the foundation is flat, solid, safe and reliable, and has sufficient bearing capacity.

5.2.2 Foundation Construction Method

Please refer to the following cabinet base structure to complete the planning and construction of the foundation.

Tip:

When the foundation is constructed, pay attention to reserving holes for cable routing.

Since most of the cables of the cabinet are thick, it will be difficult to perform cable routing operations once the cabinet is installed. Therefore, lay the power cables before the cabinet is moved to the intended installation location.

Top view of the bottom of the cabinet:

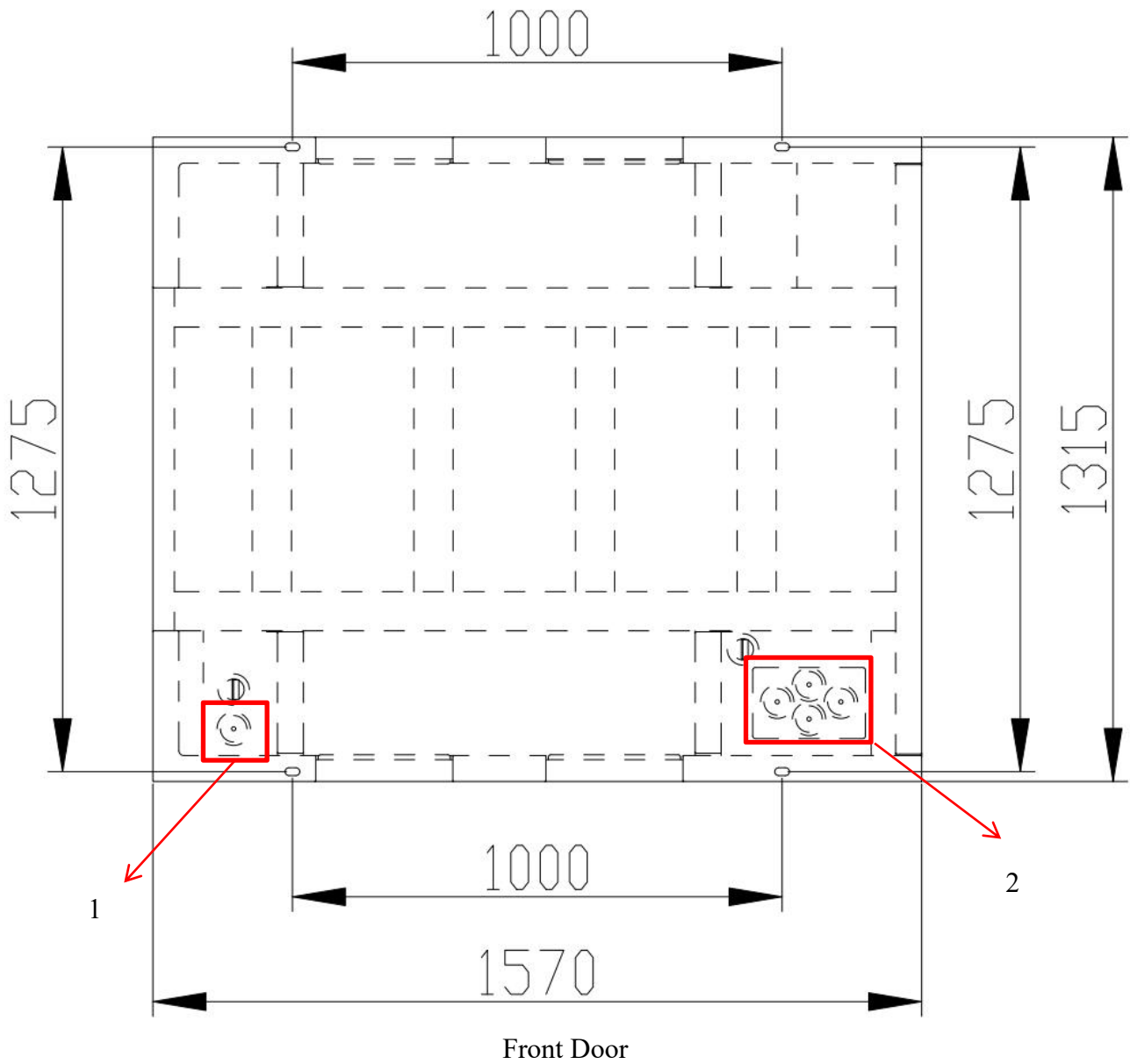
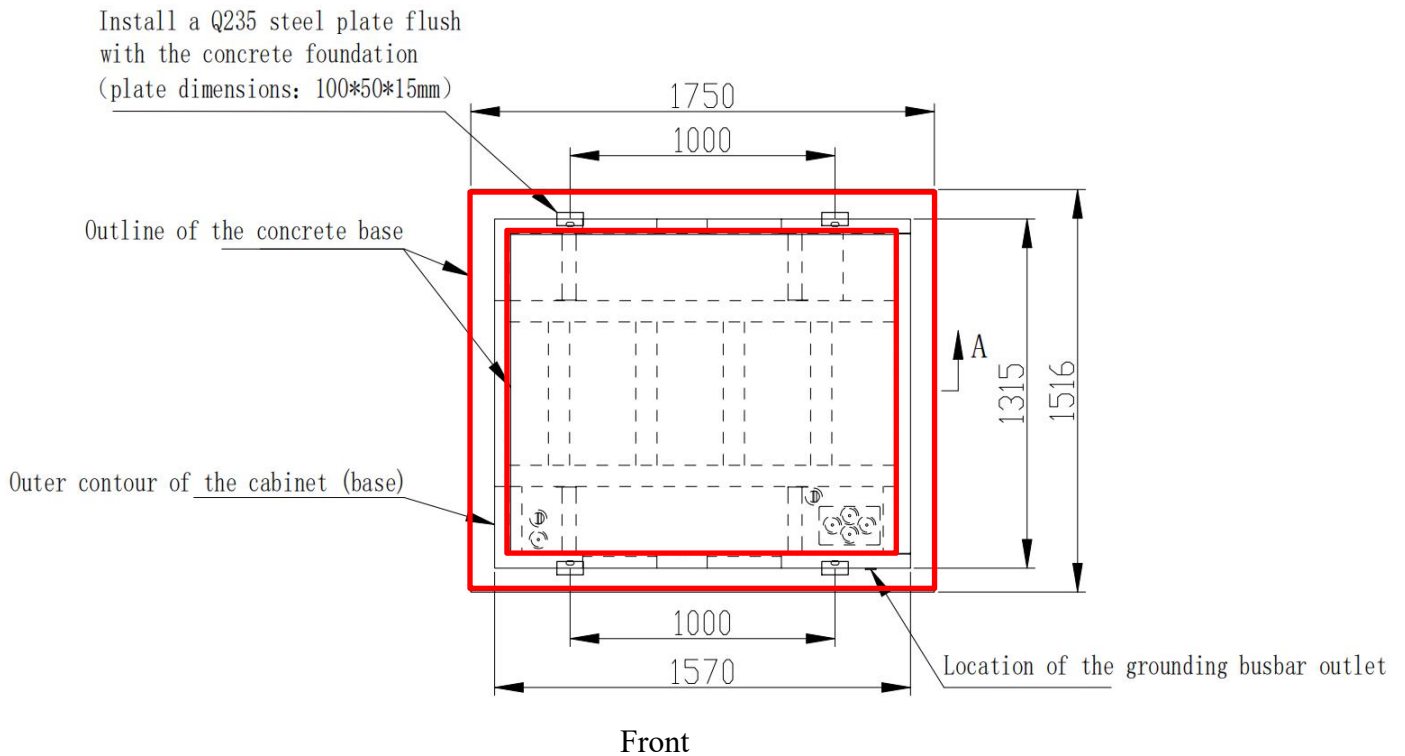

Figure Notes:

NO.	Name	Explanation
1	Secondary cable entry hole	Secondary cable input and output (Communication lines)
2	Primary cable entry hole	Primary cable input and output (The line connected to the PCS, Power supply lines)



5.2.3 Handling Equipment

(1) Handling Precautions

A. Precautions for lifting and transportation

When lifting the equipment, at least the following requirements must be met:

- Safety must be ensured at the site when lifting.
- When lifting and transportation operations are carried out, professional personnel should be involved and direct the whole process on site.
- The strength of the slings used should be able to withstand the weight of the equipment and a test lift should be attempted before transportation.
- Ensure that all sling connections are safe and reliable, and ensure that the sections of slings connected to corner pieces are of equal length.
- The length of the slings can be adjusted appropriately according to the actual requirements on site.
- Make sure that the equipment is smooth and does not deflect during the whole lifting process.
- Please use the four lifting rings of the equipment to lift the equipment.
- Make sure that the front and rear doors are locked during the lifting process, and take all necessary auxiliary measures to ensure the safe and smooth lifting of the equipment.

-
- The equipment can be lifted from the ceiling using slings with hooks or U-hooks. The lifting device should be properly connected to the equipment.

To move cabinets using lifting devices, special slings should be used, and the strength of the slings should be able to withstand the weight of the product. Before lifting, make sure that the lifting ring is installed tightly, all sling connections are safe and reliable, and make sure that each section of the sling connected to the lifting ring is of equal length to keep the cabinet balanced and avoid tilting of the cabinet resulting in the center of gravity shifting.

When lifting operation, should ensure slow and smooth, should use the tow rope to assist in adjusting the direction of the cabinet to maintain stability. The cabinet must be placed on a solid and flat ground.

During the whole process of lifting operation, relevant safety operation norms must be strictly observed, and it is strictly prohibited for people to stand under the cabinet or on the path that may be tilted.

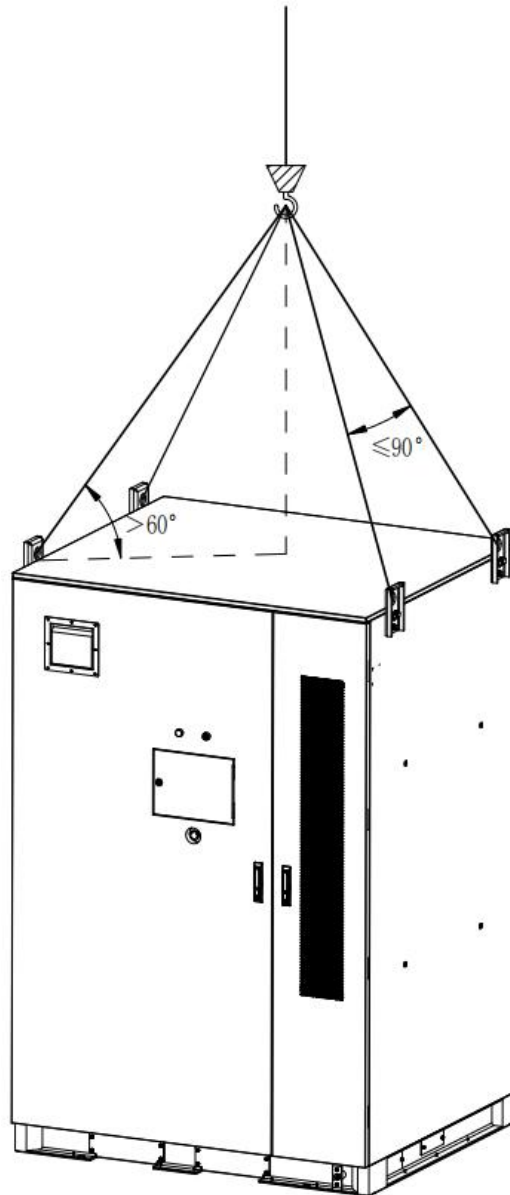

Figure 5.2.3.1 Lifting Schematic

B. Forklift Transportation Precautions

If the installation site is flat, the unit can be moved using a forklift. The bottom of the unit is equipped with fork holes designed for forklift transportation. Move the unit through the front fork holes.

If a forklift is used for transportation, the following requirements should be met:

- The forklift should be able to carry the weight of the device, the recommended forklift capacity is $\geq 3t$.
- The forklift should have appropriate leg lengths, and it is recommended that a test forklift be

used prior to transportation.

- The equipment should be kept stable during the moving process, and should not be moved up and down or tilted too much.
- Lifting and lowering should be done gently, avoiding shock or vibration, and paying attention to the ground level when moving.
- Moving should be done by professional personnel, and they should participate in the whole operation command on site.
- Make sure the front and rear doors of the cabinet are locked before moving to avoid equipment damage or personnel injury.
- Take all necessary supporting measures to ensure the safe and smooth transportation of the electrical cabinet to the target location.

Using a forklift to move the cabinet is the standard method of transportation. When handling, the center of gravity of the cabinet should fall between the two forks of the forklift and be pre-inserted to ensure that it will not tilt after being fork lifted. The fork length of the forklift should not be less than 2.1m as shown in the diagram.

When using a forklift truck to fork lift, lower and move the cabinet, it should be ensured that it is slow and smooth, and the cabinet must be placed on a firm and flat surface.

In the whole process of using forklift operation, the forklift safety operation specification must be strictly observed. Due to the large size of the cabinet, it may block the driver's vision, there should be auxiliary personnel to cooperate.

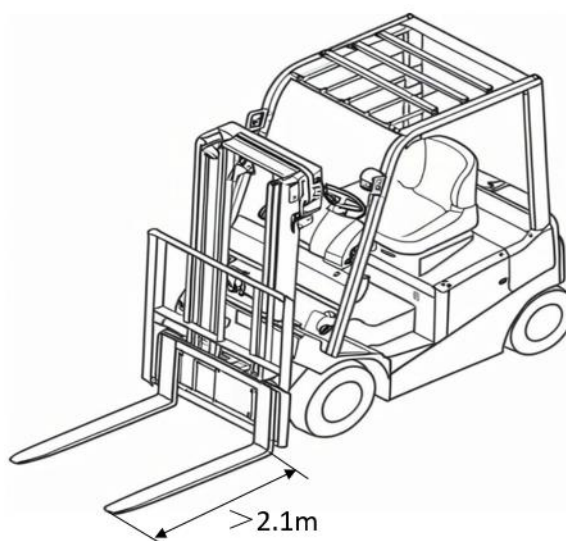

C. Precautions for transportation by pallet

Moving the equipment by pallet is only applicable when the transportation route is relatively flat. When the equipment is moved, its center of gravity should fall between the two forks of the pallet truck and be pre-inserted to ensure that it will not tilt after the fork lift. As shown in the figure, the length of the fork of the pallet truck shall not be less than 1.5m, the two fork arms of the pallet truck, the distance between the outer sides shall not be more than 0.7m, and the load-bearing capacity of the pallet forklift truck shall be more than 3t.

The use of pallet truck forks up, down and move the equipment, should ensure that slow and smooth, the equipment must be placed on a solid and flat ground.

In the whole process of using pallet truck operation, the relevant safety operation specification must be strictly adhered to. Due to the large size of the equipment, the operator's vision may be obscured, and should be accompanied by auxiliary personnel.

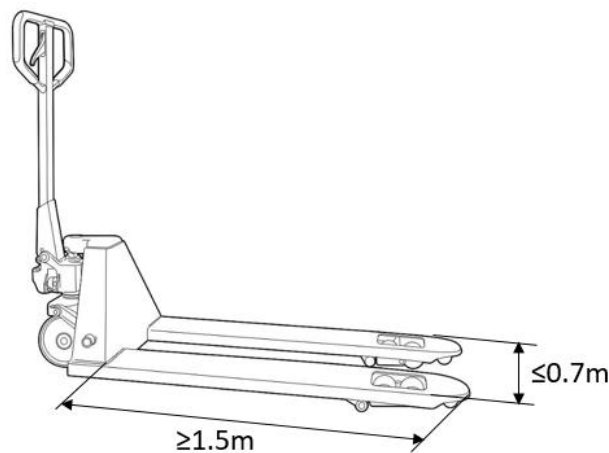

5.2.4 Fixed Equipment

The cabinet is secured to the foundation by welding Q235 connecting plates to it; when constructing the foundation, the Q235 connecting plates must be embedded in advance. After securing the equipment and connecting the cables, install the bottom panel of the cabinet.

Pre-embedded Q235 connecting plate (100*50*15mm)

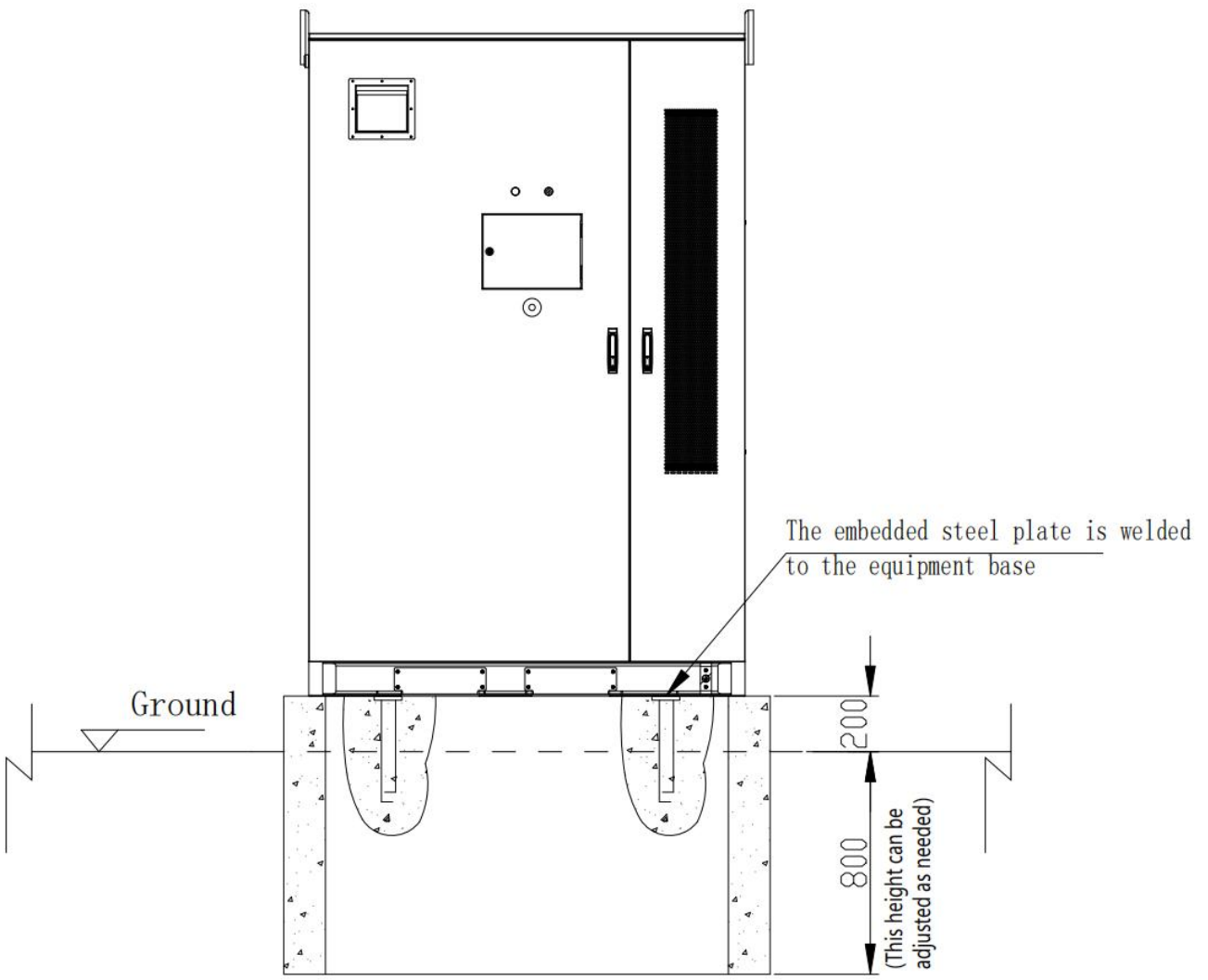
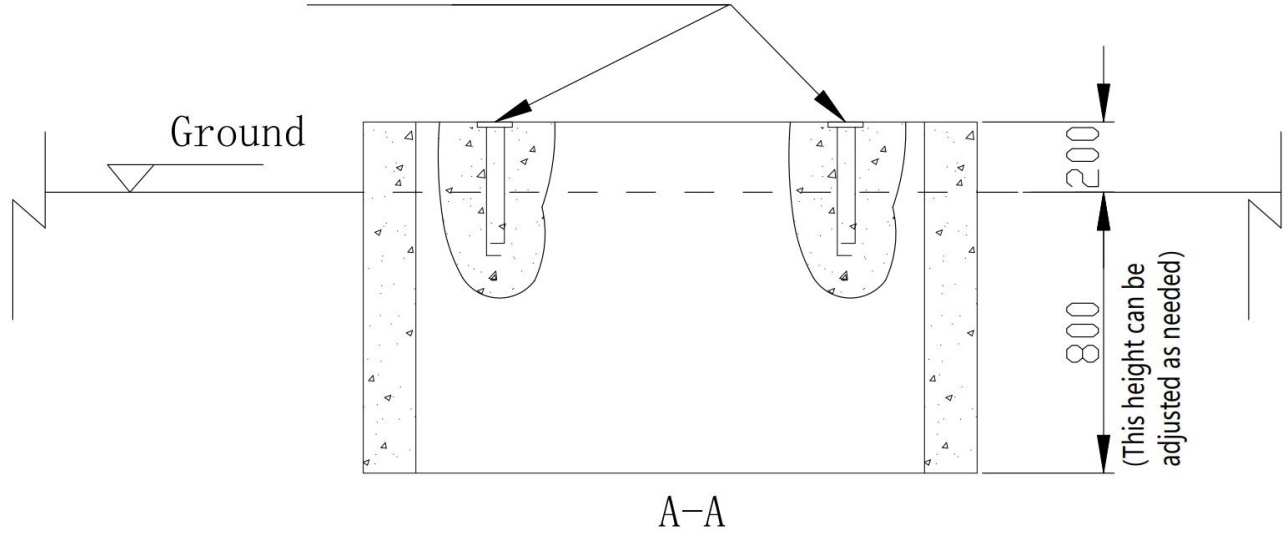

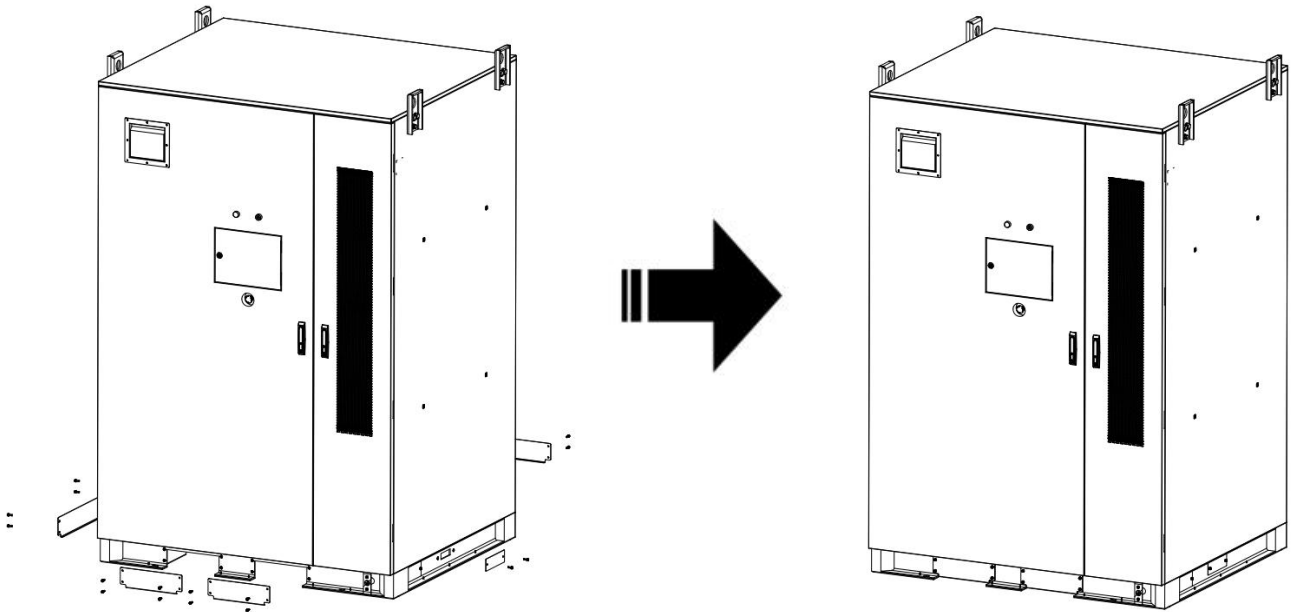

5.3 Electrical Wiring

5.3.1 Wiring Precautions

⚠ When connecting the wires, please make sure to complete them in order according to the contents of the manual, the ground connection must be completed first, and all the wiring work must be carried out in a no-voltage state. Before connecting the electrical cables, please make sure that the control box air switch, AC side air switch, miniature circuit breaker and all higher level switches are disconnected.

5.3.2 Wire Harness Specification

NO.	Wire Harness Name	Recommended wire harness specification (minimum cross-sectional area)	Terminal Specification	Note
1	PCS to equipment power line (P+, P- lines)	50mm ² /70mm ²	Battery side: Connector terminals PCS side: Customer-supplied	Cables to be provided by the customer
2	Ground line	5AWG (16mm ²)	OT terminal M6	Cables to be provided by the customer
3	Auxiliary power cable (control box power)	18AWG (0.8mm ²)	Battery side: Tubular terminal EVN7510	Cables to be provided by

	cable)			the customer
4	Auxiliary power supply line (power supply line for liquid-cooled units)	10AWG (5.2mm ²)	Battery side: Tubular terminal EVN6010	Cables to be provided by the customer
5	Communication lines with third EMS	RJ45 568B line sequence	/	If required, customer to provide
6	Communication lines with PCS	22AWG (0.3mm ²)	Battery side: Tubular terminal EVN0510	Cables to be provided by the customer

Note: Cable specifications should be selected in accordance with local cable standards. Factors affecting the selection of cables include: rated current, cable type, laying method, maximum expected line loss, rated temperature, ambient temperature, temperature resistance, acidity, settlement, environmental protection requirements and so on.

Screw Specification	Recommended Torque
M6	$5 \pm 10\%N \cdot m$
M8	$12 \pm 10\%N \cdot m$
M10	$26 \pm 10\%N \cdot m$

5.3.3 Ground Line Connection

The system's internal ground wire is connected at the time of shipment; the system's external ground wire must be connected manually on-site. Please refer to the local regulations to connect the external ground wire before wiring. Take out the ground wire (provided by the customer, wire diameter not less than 16mm²), use M6*14 screws to crimp one end to the outside of the cabinet, the specific crimping position see the following figure. The ground wire can be connected in series when paralleling cabinets.

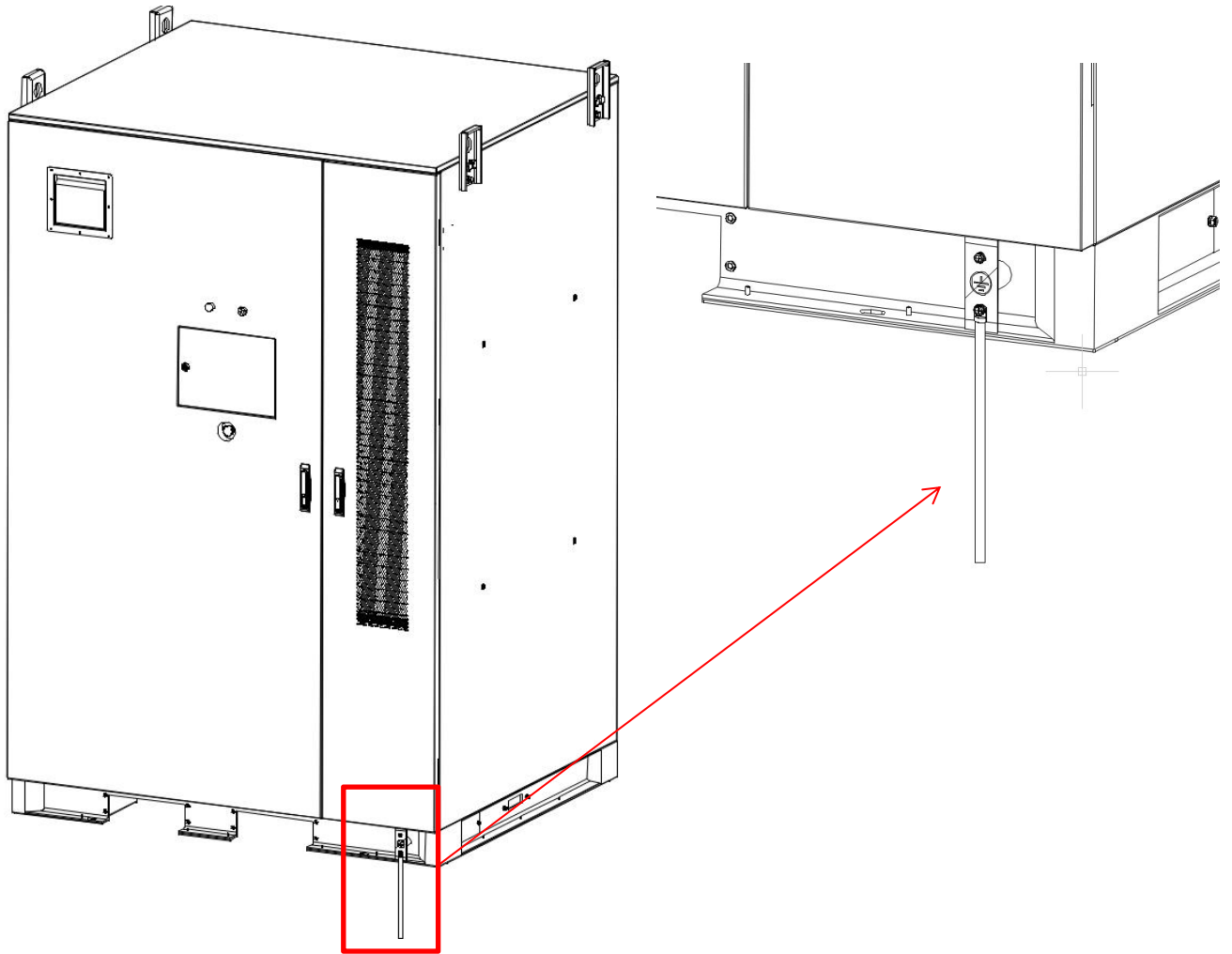

Figure 5.3.3.1 Grounding Connection Diagram

5.3.4 Power Line Connection

The power cables (provided by the customer) are primarily connected via connector terminals. The power cables are routed through the cable access port at the bottom of the cabinet's front door, while the auxiliary power cables are routed through the cable access port in the lower left corner of the cabinet. The power cables are connected to P+ and P-, the auxiliary power cables to XT2:1 and XT2:3, and the power supply for the liquid cooling unit to XT1:1 and XT1:2.

Note: The auxiliary power supply for the control cabinet can be sourced from the PCS, the utility grid, or a UPS (power ≥ 1 kW). The auxiliary power supply for the liquid cooling unit must be ≥ 5 kW.

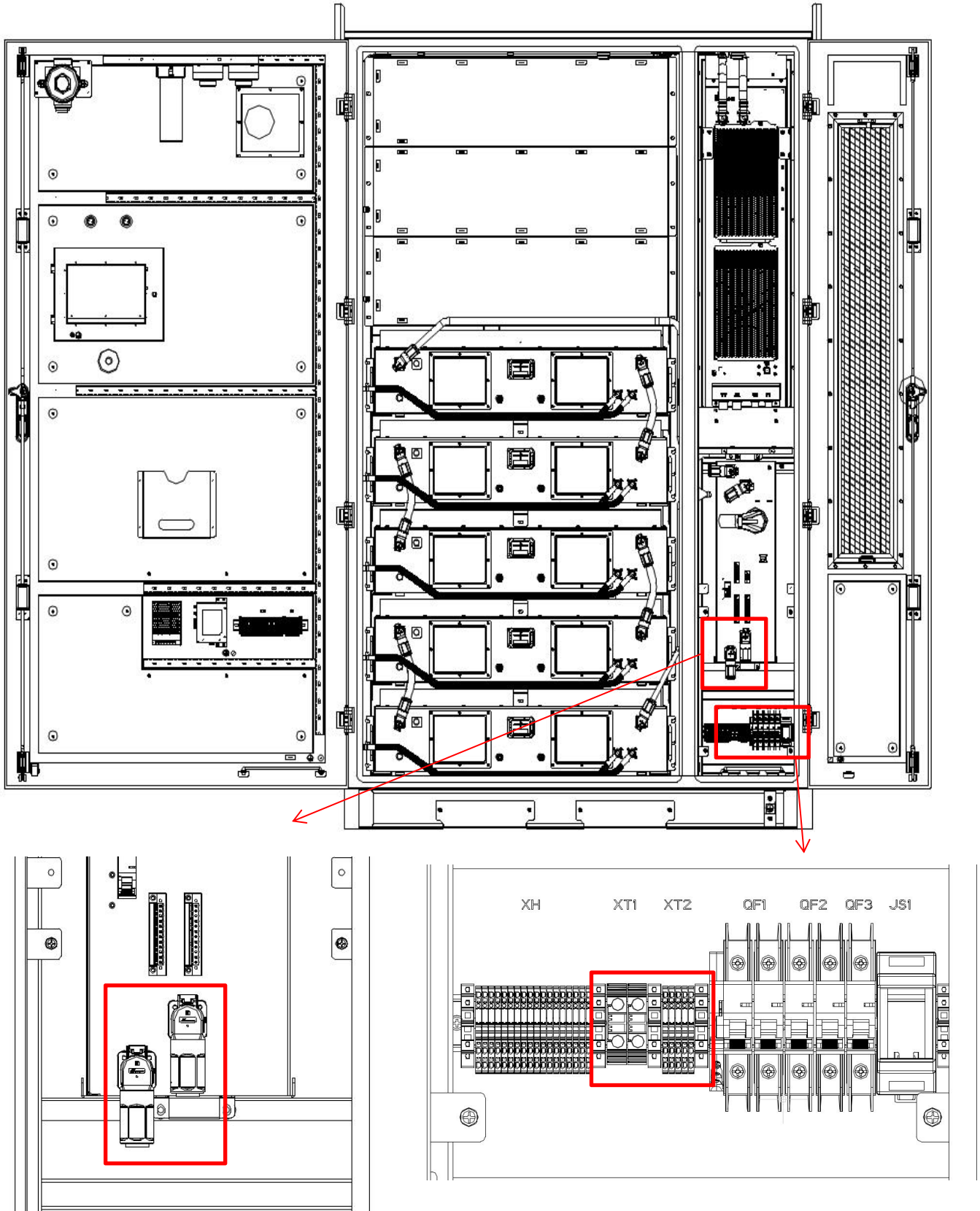

Figure 5.3.4.1 Schematic Diagram of Power Line and Auxiliary Power Supply Line Connection Locations

Auxiliary Power Cable Connection Procedure:

Step 1: Open the PC isolation plate on the AC side of the distribution box.

Step 2: Remove the terminal block screws and set them aside.

Step 3: Connect auxiliary power supply wires according to the XT1 and XT2 screen-printed positions.

Step 4: After connecting the wires, remove the screws and tighten the terminals to a torque of 20 N•m for XT1.

Step 5: Route the wire from the coil to the outside of the cabinet. Apply fireproof putty to seal the gap around the coil.

5.3.5 Communication Line Connection

The internal communication cables are pre-connected at the factory. Refer to the diagram below for their locations. The LAN communication ports are located on the LCU module. By default, LAN0 connects to the PC for local device debugging and network configuration. LAN1 connects to an external router for communication (customer-supplied; Cat5e shielded cable or higher is recommended). LAN2 serves as the cabinet-internal device communication port for data exchange and control with other cabinet equipment.

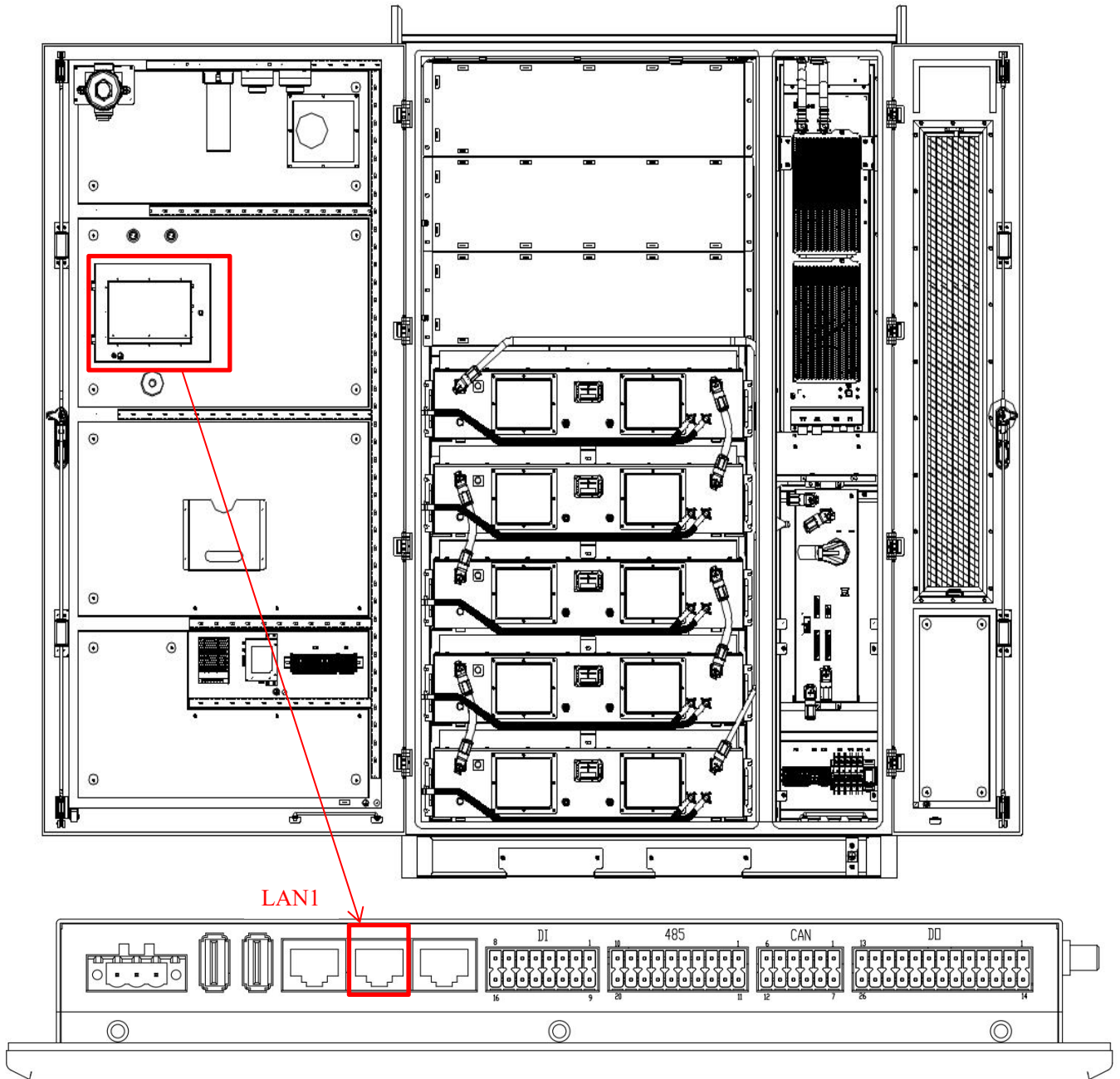

Figure 5.3.5.1 Schematic diagram of the external communication interface of the cabinet

The connection points for the PCS (XT3: 7, XT3: 8) are shown in the figure below:

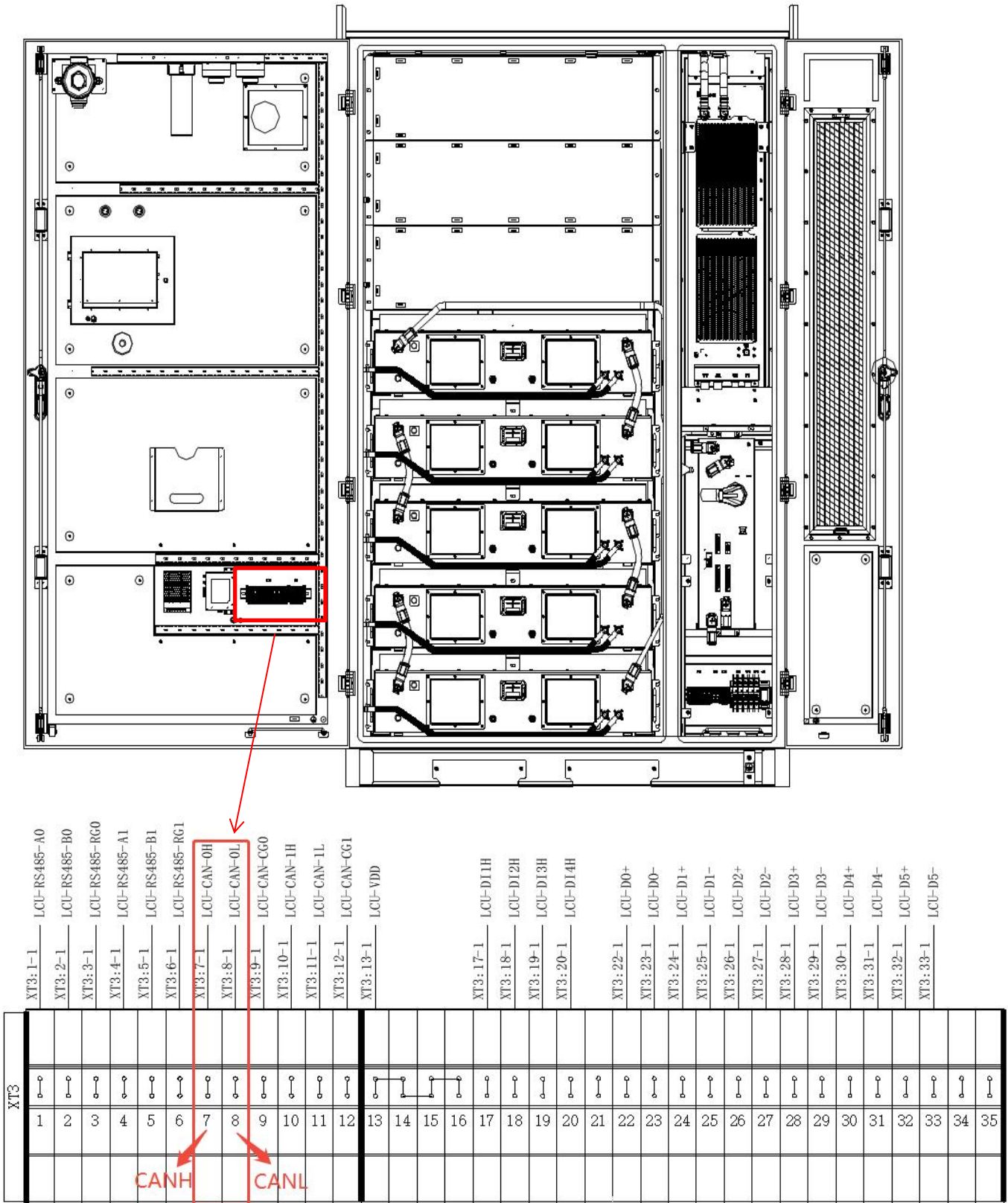

Figure 5.3.5.2 Schematic Diagram of the Cabinet's PCS Communication Interface

5.4 Installation Inspection

5.4.1 Electrical Inspection

- (1) Ground wire connection is complete. Connection is tight and secure, no leakage, wrong connection.
- (2) Power line connection is complete. Connect firmly and securely, without polarity reversal, leakage, wrong port and other phenomena.
- (3) The communication line is connected correctly. Connection is tight and reliable, no leakage, wrong connection.
- (4) The cables meet the principle of separation of strong and weak power, and the alignment is straight and smooth, without crossing.
- (5) All cables are not damaged or cracked, reasonably distributed, with appropriate margins at the turns.
- (6) Check the value of grounding resistance ($< 4\Omega$) and make sure that the ground wire is well connected to the ground network.

5.4.2 Structural Inspection

- (1) The equipment is well installed and free from breakage, rust and paint loss. If so, please refill the paint in time.
- (2) Equipment label is clearly visible. If it is broken, please replace it in time.
- (3) The equipment is firmly and stably installed, and the surrounding space meets the requirements.
- (4) The equipment surrounding is clean and tidy, and there is no construction leftovers inside the equipment.
- (5) The protective cover and baffle plate removed during wiring have been re-installed, and there is no missing installation.

VI. Equipment Operation

6.1 Indicator Light Introduction

6.1.1 Cabinet Indicator Light

NO.	ALM	RUN	Note
1	OFF	Always on	System power-up enable
2	Always on	Always on	System failure

6.2 Operation Guidance

6.2.1 Pre-operation Inspection

- 1) Before proceeding to the next step of powering up the equipment, please read carefully “I. Safety Statement” of this manual and make a detailed inspection.
- 2) When operating or maintaining the internal metal parts of the equipment, the voltage to the enclosure (protective ground) must be checked with a high-voltage tester or other instrument to prevent electric shock.

After the installation of the equipment is completed, you need to check the following contents carefully and item by item before applying the power:

1. Please read “I. Safety Statement” carefully.
2. Confirm that the equipment is not damaged, scratches and other signs.
3. To confirm that the equipment cabinet, cabinet tops without leaving foreign objects.
4. Confirm that there is enough space around the equipment for maintenance and operation.
5. To confirm that there is no explosive, flammable materials around the equipment.
6. Confirm that the system input switch in the field is disconnected, all the power wiring is correct, all the communication line cable connection is correct.
7. Confirm that the equipment has been well grounded.
8. Confirm that the equipment has been set up around the isolation zone and warning signs to prevent others from misuse or close.

6.2.2 Power-up Procedure

- 1、 Connect the MSD maintenance switch of the DC circuit.

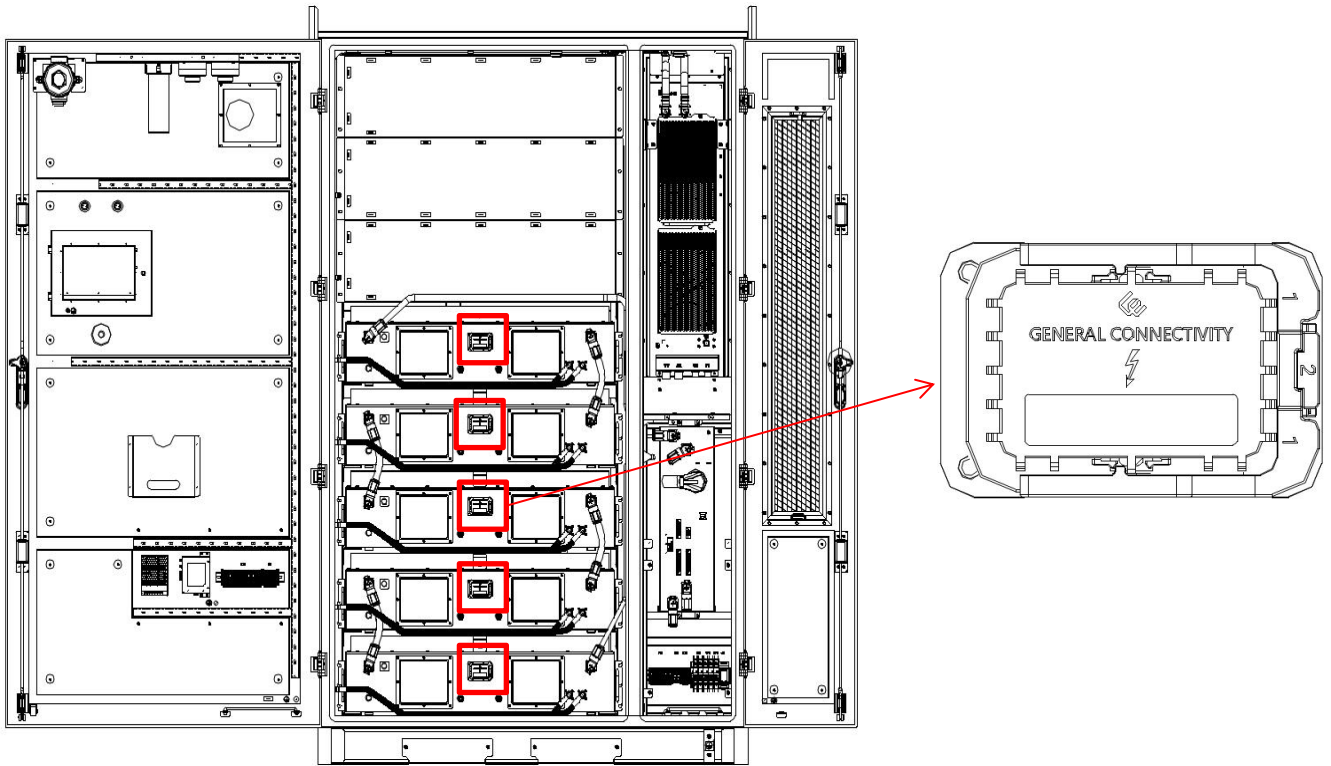
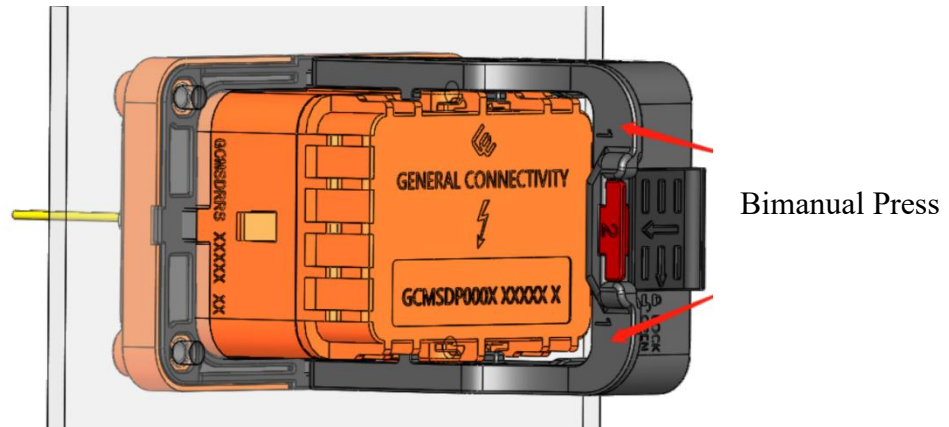
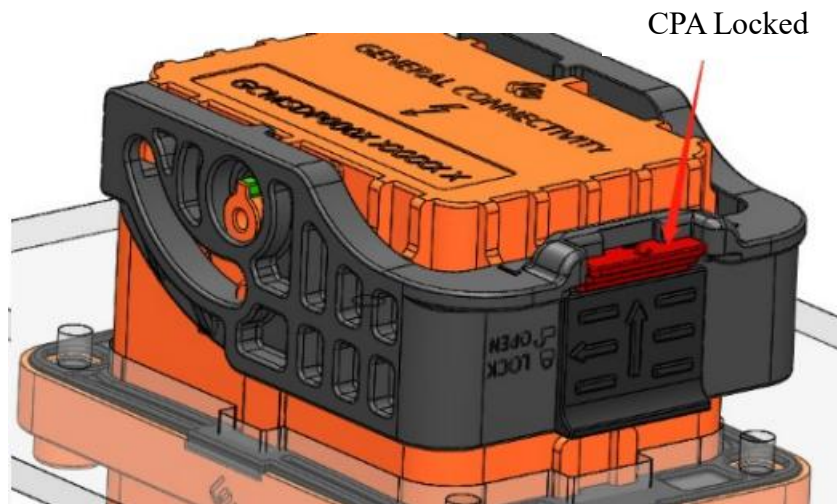

Figure 6.2.2.1 Schematic diagram of the maintenance switch



MSD plugs and sockets are designed for mutual compatibility. With the CPA in the open position, simultaneously press down on handle “1” of the MSD. Upon hearing a “click,” the handle is fully locked.



After the handle is fully locked, press down on the MSD CPA. Push the CPA until the unlocking slider is flush, achieving the secondary locking effect of the MSD CPA.

2、 Close the disconnecter QS of the control box, set QS to the “ON” position.

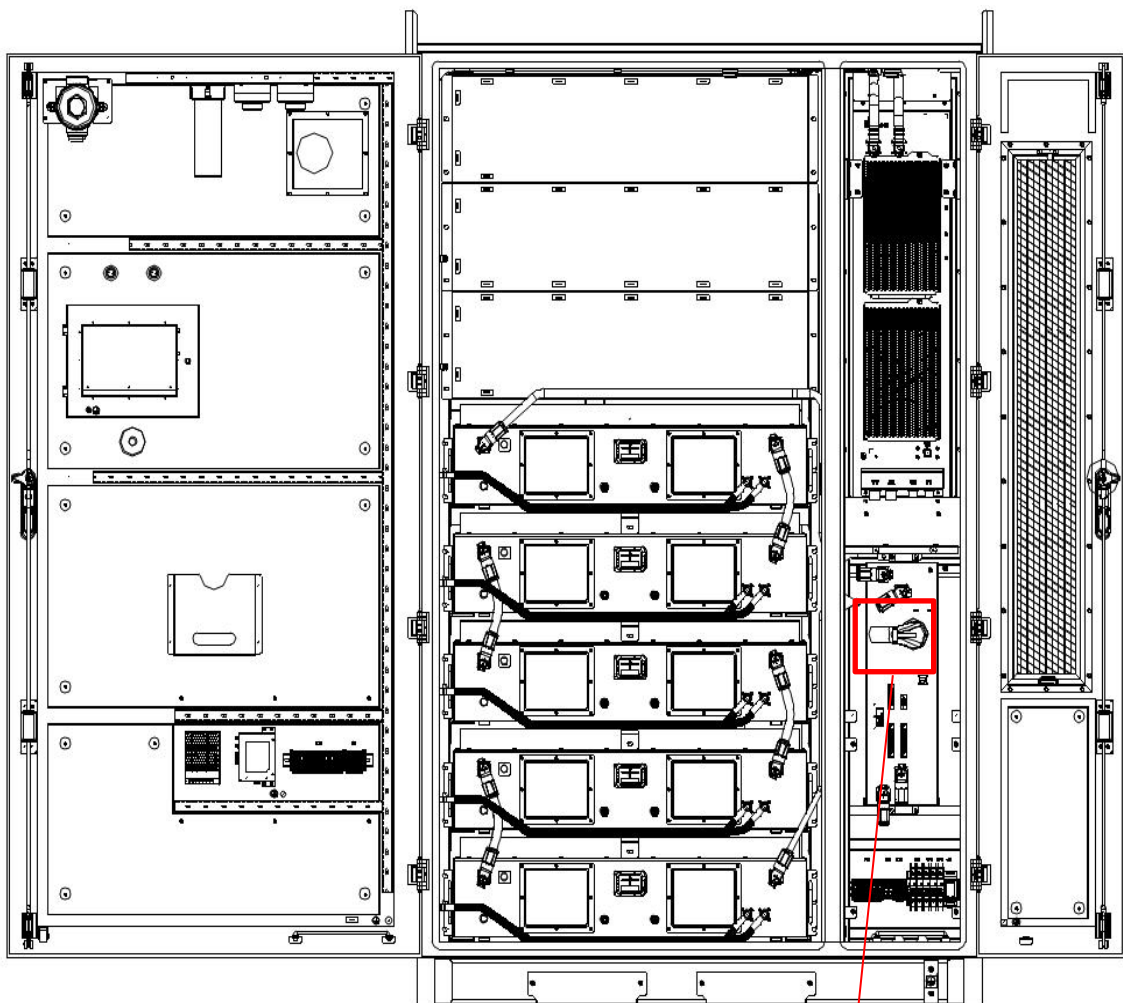

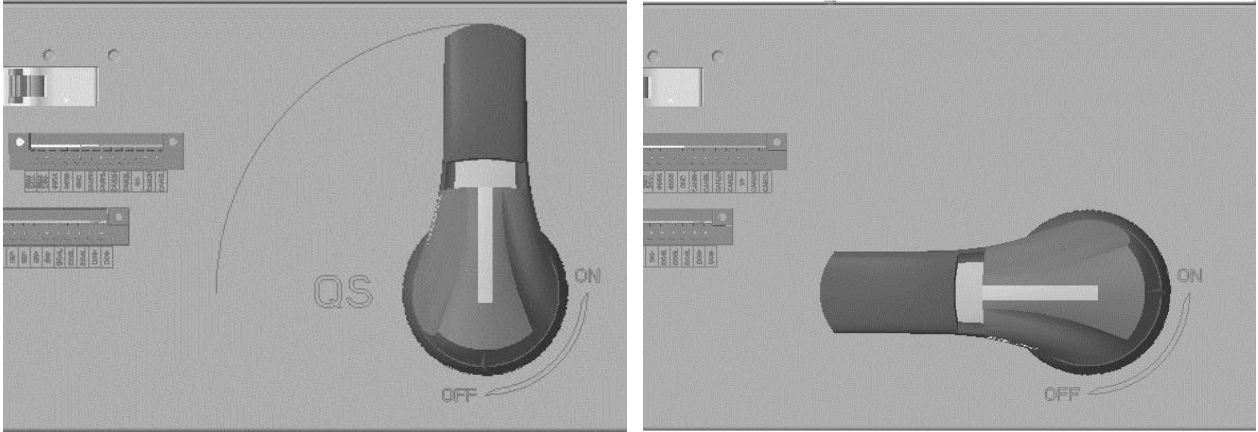

Disconnected State

Closed State

Figure 6.2.2.2 Schematic diagram of the control box

3、Close the auxiliary power supply switches in sequence (QF1, QF2, QF3, QF).

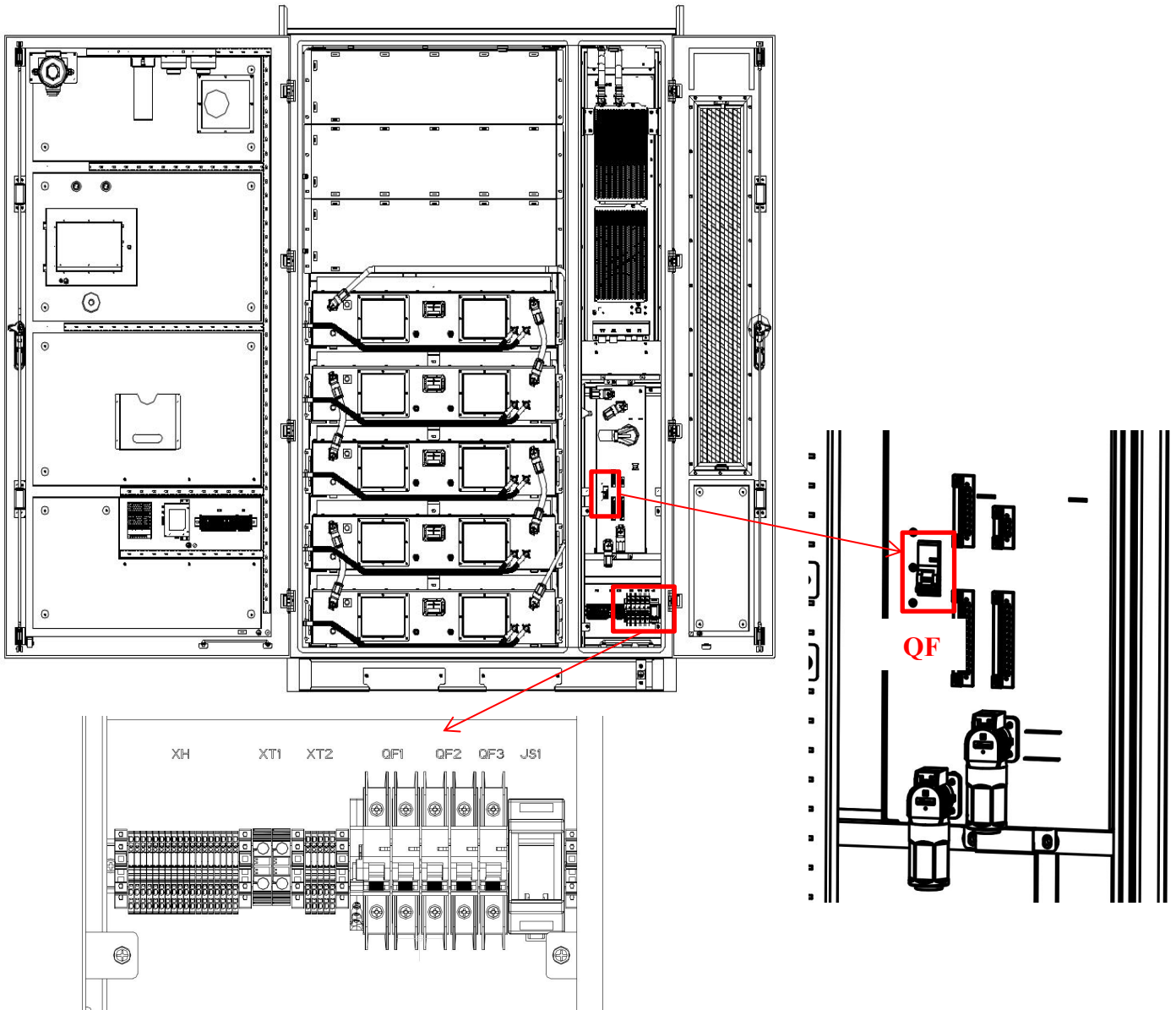

Figure 6.2.2.3 Schematic diagram of each switch

4、Click the LCU screen to enter the user operation interface (the default permission is user permission, Username: general Password: 729735), and the current status of the system can be displayed normally.

6.2.3 Turn off the Power

(1) Shutdown steps

Set the device to shut down using the touch screen.

Hint:

This shutdown mode only turns off the operation of power devices in the system. The machine is in standby mode, and the output terminals remain powered.

(2) Power-off step

Step 1: Shut down the main power supply: Turn off the switch (QF).

Step 2: Shut down the auxiliary power supply and the liquid cooling unit power supply: Turn off the AC auxiliary power supply switches (QF1, QF2, QF3).

Step 3: Disconnect the DC circuit: Turn off the circuit breaker QS in the high-voltage control cabinet; set QS to the OFF position.

6.2.4 Emergency Shutdown

In case of an emergency, pressing the emergency stop button on the cabinet door will immediately cut off the primary circuit inside the cabinet and stop the charging and discharging path.

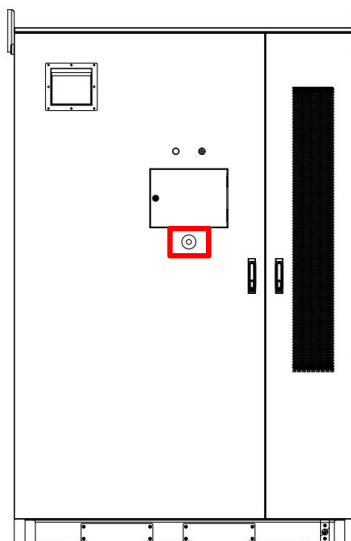

VII. Maintenance Guidance

7.1 Maintenance Precautions

1) Before maintenance, it is necessary to use high-voltage testers or other instruments to test the metal parts that need to be touched or may be touched to avoid electric shock.

2) During maintenance, please pay attention to the warning labels inside the equipment to prevent personal injury caused by high-temperature, overweight and other components.

3) Maintenance must be carried out when the system is shut down and not energized, and the following steps should be followed:

Shut down the equipment.

② Disconnect all external power sources.

③ Confirm that the pre-stage switch has been disconnected and the grounding knife switch is properly connected.

After maintenance, all screws need to be tightened to the required torque.

4) The model of the new device replaced must be consistent with the original one. If you have any questions, please contact Sunwoda.

5) Daily inspections of the equipment can be carried out by personnel who have received relevant training, and the inspection and replacement of its components should be operated by authorized professionals.

6) The components behind the protective cover plate that can only be opened with tools are not accessible to users. Only qualified maintenance personnel are allowed to open such protective cover plates.

7.2 Maintenance Content

Due to the influence of factors such as humidity, temperature, dust and vibration in the operating environment, the internal components of energy storage systems that have been in use for a long time may experience varying degrees of aging or performance degradation. After the equipment is put into use, please be sure to inspect it regularly. The inspection items are as follows:

Inspect the Component	Inspection Content	Inspection Cycle
LCU Touch screen	① Check whether there are any fault alarm messages in the interface that have not been processed	Once a week
	② Check whether there are any changes in the parameter Settings of the interface	Once a month
	③ Check the operation data of the system and export and save it to relevant files (including operation logs)	Once a month
	④ Check whether the start-stop control function of the interface is operating normally	Once six month
	⑤ Check whether the resolution status of the interface has decreased or shown any abnormalities	Once a year
Cabinet Note: For any operation that requires touching the cabinet, please make sure to power off the cabinet and wait for 15 minutes before proceeding	① Check whether the operating noise of the cabinet is too loud or there are any abnormal sounds	Once three month
	② Check whether the outer wall of the cabinet has abnormal temperature	Once three month
	③ Check the surrounding environment of the cabinet for any accumulated water, dirt, heat sources or other items, and remove them in time	Once a month
	④ Check whether there is any dust accumulation at the air inlet and outlet of the cabinet. Is there too much dust or object covering the top of the cabinet	Once six month
	⑤ Check whether the cabinet shell shows signs of rust, oxidation, damage, paint peeling, etc	Once a year
Wiring harnesses and terminal blocks Note: Please be sure to power off the system and wait for 15 minutes before conducting any relevant inspection operations	① Check whether the power, communication and ground wire connections are loose	Once a year
	② Check whether the insulating skin of the power, communication and ground wires is damaged	Once a year
	③ Check whether the insulating winding tape of the power line is damaged	Once a year
	④ Check whether the terminal blocks or copper bars are loose or have rust or oxidation	Once a year
Fire protection devices such as smoke sensors, temperature sensors, fire water connectors, etc.	① Regularly check the sensitivity of the smoke sensor by using controllable smoke	Once a year
	② Regularly check the response sensitivity of the smoke sensor using a controllable heat source	Once a year
	③ Regularly open the upper cover of the fire water connection and check if it is rusty	Once a year

VIII. Fault Handling

NO.	Report Unit	Fault Description	Possible Reason	Solution
1	LCU	The PCS communication is disconnected	The communication line connection is abnormal, or the LCU communication parameters are configured incorrectly	1. Check the communication line between the LCU and the PCS. 2. Check whether the PCS model selected on the LCU is consistent with the actual model.
2	LCU	The BMS communication is disconnected	The communication line connection is abnormal, or the LCU communication parameters are configured incorrectly	Check the communication line between the LCU and the BMS
3	BMS	Emergency stop switch failure	Emergency stop switch triggered	Reset the emergency stop switch
4	BMS	The cabinet door is open	The cabinet door is not closed properly	Check the condition of the cabinet door
5	BMS	The smoke/temperature sensor is alarming	The connection of the sensor feedback line is abnormal, or the sensor is faulty	Check the wiring of the sensor or contact the manufacturer for handling
6	BMS	Fire trigger	The connection of the feedback wire of the fire extinguisher is abnormal	Check the wiring of the fire extinguisher or contact the manufacturer for handling
7	BMS	The cabinet is flooded	The wiring of the water immersion sensor is abnormal, or the water immersion sensor is faulty	Check the wiring of the water immersion sensor or contact the manufacturer for handling
8	BMS	There is severe overcurrent during charging	Abnormal current sampling	Please contact the manufacturer
9	BMS	There is severe overcurrent during discharging	Abnormal current sampling	Please contact the manufacturer
10	BMS	The battery is severely overvoltage	Abnormal voltage sampling	Please contact the manufacturer
11	BMS	The battery is severely undervoltage	Abnormal voltage sampling or the battery has not been charged for a long time	Please contact the manufacturer
12	BMS	The battery is severely	The power switch for the fan or air	Close the power switch of the fan and the power switch of the

		overheated	conditioner is not closed	air conditioner
13	BMS	Severe low temperature of the battery	The power switch for the fan or air conditioner is not closed	Close the power switch of the fan and the power switch of the air conditioner
14	BMS	Abnormal high-voltage sampling	The DC circuit breaker of the high-voltage box is not closed	Close the DC circuit breaker of the high-voltage box
15	BMS	The temperature of the main control box is abnormal	The power supply switch for the high-voltage box fan is not closed, or the power supply switch for the cabinet fan is not closed	Close the power supply switch of the fan
16	BMS	Abnormal liquid-cooled unit communication	The power switch for the liquid-cooled unit is not closed	Close the power supply switch of the liquid-cooled unit



Sunwoda Energy Technology Co., Ltd

Sunwoda Industrial Park, No.18 Tangjia South Road, Guangming New District, Shenzhen, China

www.sunwodaenergy.com