

OASIS L241

241kWh Liquid Cooled Battery Cabinet

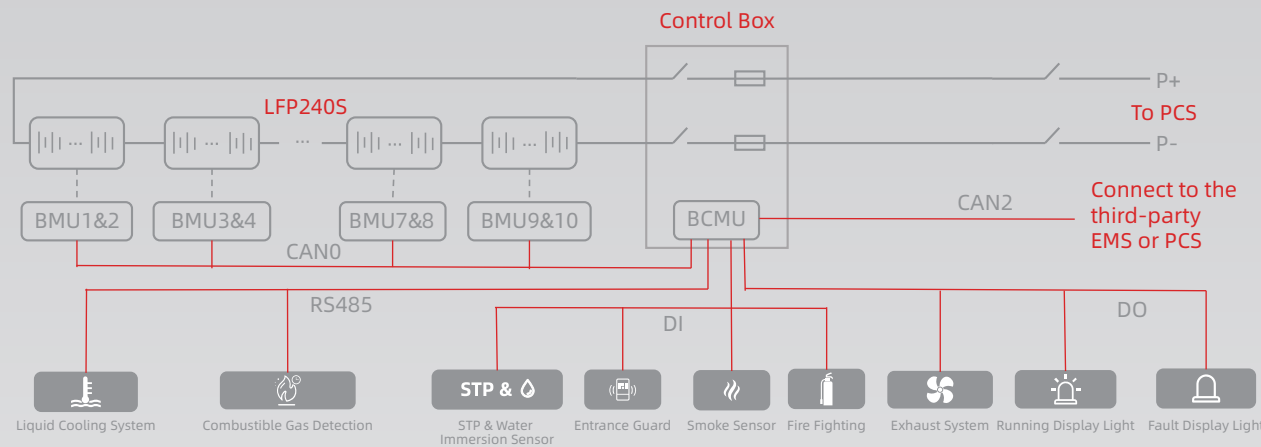

Application Scenario



PV and Storage Integration

OASIS L241 supports external hybrid inverter, DC coupling access to photovoltaic, integrated system design, one-stop service, high system integration, flexible layout of the scheme, can reduce light abandonment, improve the utilization rate of photovoltaic power generation.



Peak shaving and valley filling

After the OASIS L241 external energy storage inverter is connected, the user charges the energy storage system when the price is low, and takes electricity directly from the energy storage battery without purchasing electricity from the grid during the peak time, thereby avoiding the peak price and reducing the electricity cost.



Emergency Backup

OASIS L241 external hybrid inverter is also suitable for applications that require high continuity of the power grid. When the power grid is cut off, it can be used as a backup power supply to replace the traditional UPS power supply function, and provide backup power supply protection for the critical uninterruptible load in the industrial and commercial park to cope with sudden power failure.



Micro-grid

OASIS L241 can form a microgrid system with inverters, photovoltaic arrays, loads, diesel generators, etc. which is widely used in remote mountain areas, areas without electricity, islands, communication base stations and other places.



Cloud Platform Scheduling

OASIS L241 supports external intelligent LCU system, real-time status monitoring and fault recording, fault warning and fault location; Supports external cloud platform functions to achieve remote scheduling, cluster control, and energy efficiency management, enabling global assets to be visualized and digitized, and improving management efficiency.

OASIS L241

Single Cluster Solution

Model Type	OASIS L241
Rated energy	241kWh
Cell Specification	3.2V 314Ah
PACK Capacity	48.2kWh
No. of modules	5
Rated voltage	768V
Voltage range	624-876V
Max. C-rate	0.7C
Ambient temperature	-30°C~55°C
Working relative humidity	0~95% (no condensation)
Altitude	2000m
Cooling method	Liquid cooling
Fire suppression system	Cluster level aerosol agent fire suppression+Combustible gas detection and ventilation linkage+Explosion-proof Valve
Auxiliary power supply	220VAC/50Hz
Communication interface	CAN/RS485/Ethernet
Enclosure protection rating	IP55
Cell Cycle Life	9000 times (25°C, 0.5C/0.5C, 90%DOD, EOL70%)*
Dimensions	1570*2380*1350mm (W*H*D)
Weight	2520kg
Accreditation	CE/IEC62619/UL1973/UN38.3/IEC62477

* For warranty instructions, please refer to the warranty terms.

Approved Compatibility List of Inverter Brands

Inverter brand	Inverter model	SUNWODA ENERGY BATTERY SERIES	
		OASIS L241	
SMA	Sunny Island X 30/50	✓	
KACO	92.0 TL3-S	✓	
ATESS	PCS100/PCS250/PCS500/PCS630/PCS1000 HPS100/150-HV	✓	
GROWATT	WIT 50K-HU/WIT 63K-HU/WIT 75K-HU/WIT 100K-HU	✓	
Sinexcel	PWS1-500KTL-EX	✓	
Megarevo	MPS0100/MPS0150/MPS0250/MPS0500	✓	
SOLINTEG	M2HT-25K/30K/40K/50K-150 M2HT-75~125K-300	✓	
Deye	SUN-60/70/75/80K-SG02HP3-EU-EM6	✓	
Solis	S6-EH3P(75-125)K10-NV-YD-H	✓	
Sunwoda	OASIS Power(200、400kW)	✓	



SUNWODA ENERGY

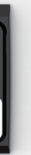
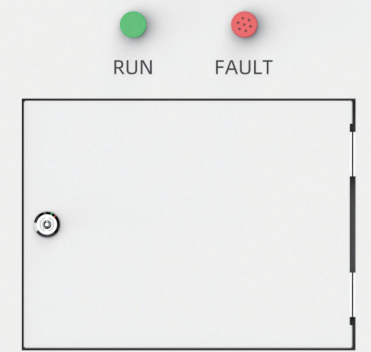

OASIS L241

OASIS L241

| 241kWh Liquid Cooled Battery Cabinet



Multi-Output Power

The inverter with different power can be selected.

High Performance BMS

Multi-level distributed architecture, neural network intelligent SOC and SOH algorithm

Multi-protection Design

Cluster level + system level + active explosion venting + exhaust system + combustible gas detection + water fire interface + partition safety isolation

Flexible Installation

Modular, plug and play, parallel expansion

High Level of Protection

Sealed liquid cooling system, Pack-level IP65, cabinet level C4 anti-corrosion grade, strong environmental adaptability

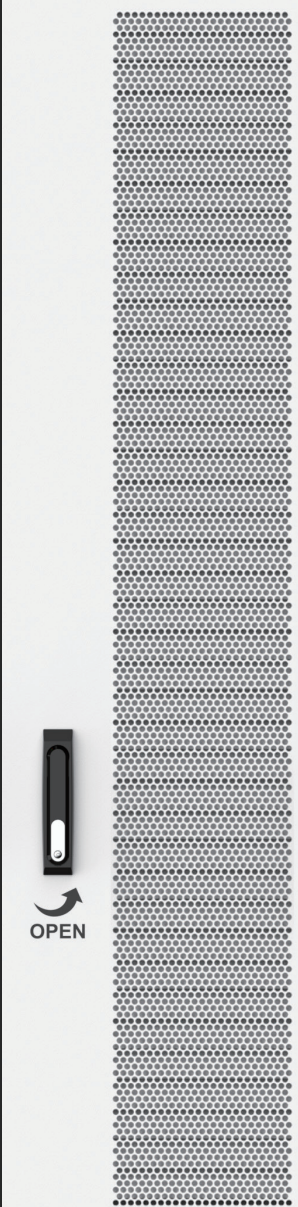

Highlights

9000 cycles

SUNWODA self-developed long life Cells are selected

kWh-MWh+

Supports parallel capacity expansion

100%DOD

Discharge depth up to 100%, maximize economy

C4/IP65

C4 anti-corrosion grade, Pack-level IP65, cabinet IP55, strong environmental adaptability



www.sunwodaenergy.com

SUNWODA ENERGY TECHNOLOGY CO., LTD.

Address: 15th Floor, Building B, Sunwoda Industrial Park, No. 18 Tangjianan Road, Guangming District, Shenzhen, China
E-mail: info@sunwoda.com Tel: +86 755 2267 0380